

SERVICE MANUAL U - COFFEE MACHINES



U (C and D)

C50 / D50





CONTENTS

1	General safety notes	5
2	Main components	6
2.1	Overview	6
2.2	Interior view	7
2.3	Fluid system	8
3	Technical data	9
3.1	Rating plates	9
3.1.1	Examples of brand specific rating plates	9
3.1.2	Rating plate details (example)	10
3.2	Technical specifications	11
3.2.1	Dimensions and weight & size	13
4	Operation	14
4.1	General information	14
4.2	Status indication	14
4.3	Machine modes	17
4.4	Empty water system	19
5	Maintenance	20
5.1	Descaling	20
5.1.1	Descaling procedure	20
5.2	Cleaning procedure	22
6	Troubleshooting	23
6.1	Check list	23
7	Repairs	25
7.1	Safety instructions	25
7.2	Repair and mounting tips	25
7.3	Tools and accessories	26
7.4	General disassembly	27
7.4.1	Prepare coffee machine for disassembly	27
7.4.2	Remove cover	28
7.4.3	Remove front cover and drop stop	29
7.4.4	Remove slider chassis and slider unit	30
7.4.5	Remove pivot bottom, cable bracket, power cable	32
7.4.6	Remove electronic device	33
7.4.7	Remove flowmeter (FM) PCB	34
7.4.8	Remove high pressure connector	35
7.4.9	Remove pump	35
7.4.10	Remove brewing unit device and steam cover	36
7.4.11	Remove BU housing and gear wheels	37
7.4.12	Remove thermoblock and capsule cage	39



7.5	Wiring diagrams	40
7.5.1	Wiring diagram 220 V - 240 V IEC	40
7.5.2	Wiring diagram 120 V UL (USA / Canada)	41
7.5.3	Wiring diagram 127 V IEC (Brazil).....	42
7.5.4	Wiring diagram 127 V IEC (Mexico)	43
7.5.5	Wiring diagram 100 V IEC (Japan)	44
7.5.6	Wiring diagram 110 V IEC (Taiwan).....	45
8	Function tests	46
8.1	Safety instructions	46
8.2	Required equipment	46
8.2.1	Overview.....	46
8.3	Measure coffee temperature.....	47
8.4	Tightness and leakage checks.....	48
8.4.1	Preparations	48
8.4.2	Test run	49
8.5	Protective earth (PE) continuity test	50
8.5.1	What is the protective earth continuity test about?	50
8.5.2	General.....	50
8.5.3	Test sequence	51
8.5.4	What to do if the protective earth continuity test fails	52
8.6	Protective insulation test.....	52
8.6.1	What is the protective insulation test about?	52
8.6.2	General.....	52
8.6.3	Test sequence	53
8.6.4	What to do if the insulation test fails	54
9	Explosion drawings.....	55
9.1	C50 Explosion drawing	55
9.2	D50 Explosion drawing.....	56
10	Parts list	57
10.1	Nespresso C50 and D50	57



i Please keep this manual together with the corresponding service documentation. This way you are assured to have the necessary information.

i Access is restricted and can be obtained by asking your Nespresso technical contact person.

PREFACE

The purpose of this service manual is to provide the service personnel with all necessary information with regards to correct handling, maintenance and repair of the U coffee machines C50 and D50.

This manual should be used by the technicians as a valuable aid to guarantee the permanent readiness for use of the machines. In order to take full advantage of all the functions, it is absolutely necessary to follow the instructions in this manual.

Only use original spare parts from your official supplier for maintenance and repair work. Spare parts lists and exploded drawings are subject to change. To obtain the last version, please contact your official spare parts supplier.

Visit the Nespresso technical website periodically to check for upgrades, technical modifications, counter measures etc. for these coffee machines:

<https://business.nespresso.com>

CONTENT UPDATES

Version 1.0

- First released service manual version, in English only.
-

Version 1.1

- Updated version including several corrections, in English only.
 - Change machine name from Pulse to U
 - Update of several drawings
 - Modified operating procedures for the following machine modes:
 - Brewing mode / programming mode
 - Descaling mode
 - Emptying mode
 - Resetting mode
-

Version 1.2

- Function test added: Tightness and leakage checks
-



1 GENERAL SAFETY NOTES

The repair of these machines can only be performed by Nespresso approved after-sales centers and technicians, using suitable tools and original spare parts and taking into account the national safety regulations.



Risk of fatal electrical shock and fire!

Mains voltage inside the coffee machine.

- **Unplug appliance before cleaning.**
- **Never clean wet or immerse plug, cord or appliance in any fluid.**
- **Disconnect the mains plug before disassembly - the appliance must be free of voltage.**

As an additional safety measure, the use of a residual current device (RCD), also called a ground fault circuit interrupter (GFCI), in the repair centre is highly recommended.

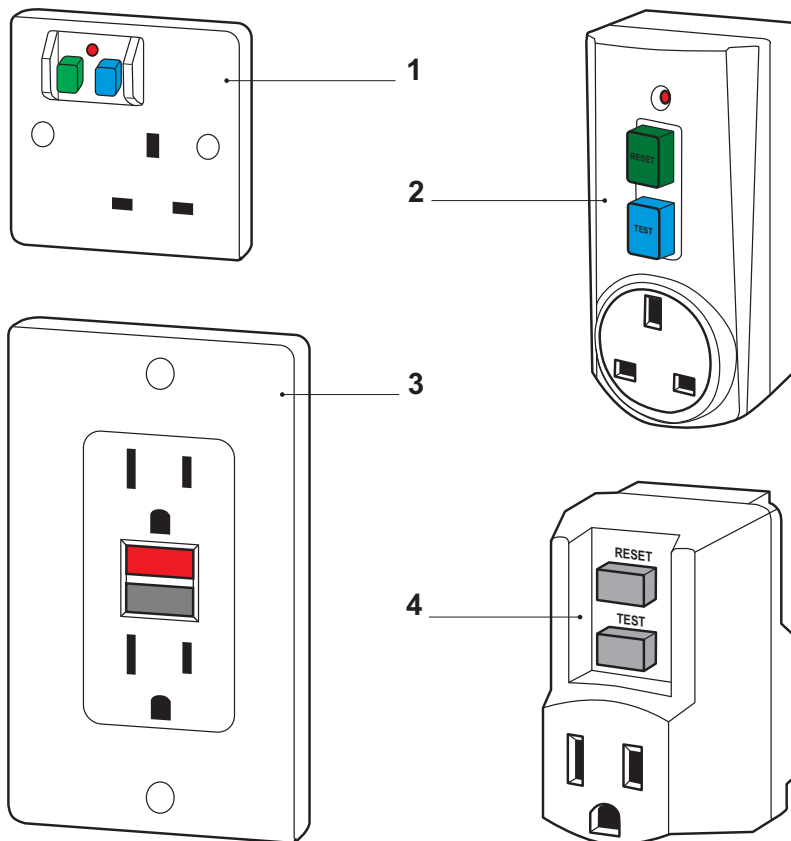

- 1) RCD protected socket-outlet
2) Plug-in RCD unit

- 3) GFCI socket
4) Plug-in GFCI



This device does not protect against electrical shock due to contact with both circuit conductors.



Example illustrations of typical devices.



Use a GFCI with a trip level of 4 - 6 mA (USA) resp. a RCD with a trip level of 15 - 30 mA (Europe). A trip level above 30 mA provides only very limited protection against harm from an electric shock.



Danger of burns!

Hot parts and water under pressure inside the coffee machine (particularly in the thermoblock).

- **Let coffee machine cool down before cleaning or disassembly.**



2 MAIN COMPONENTS

2.1 Overview



- | | |
|-----------------------------------------|--------------------------|
| 1) Capacitive touch area | 5) Coffee outlet |
| 2) Slider for capsule insertion slot | 6) Swivel water tank arm |
| 3) Used capsule container and drip tray | 7) Water tank |
| 4) Removable cup support and drip grid | 8) Water tank lid |



2.2 Interior view

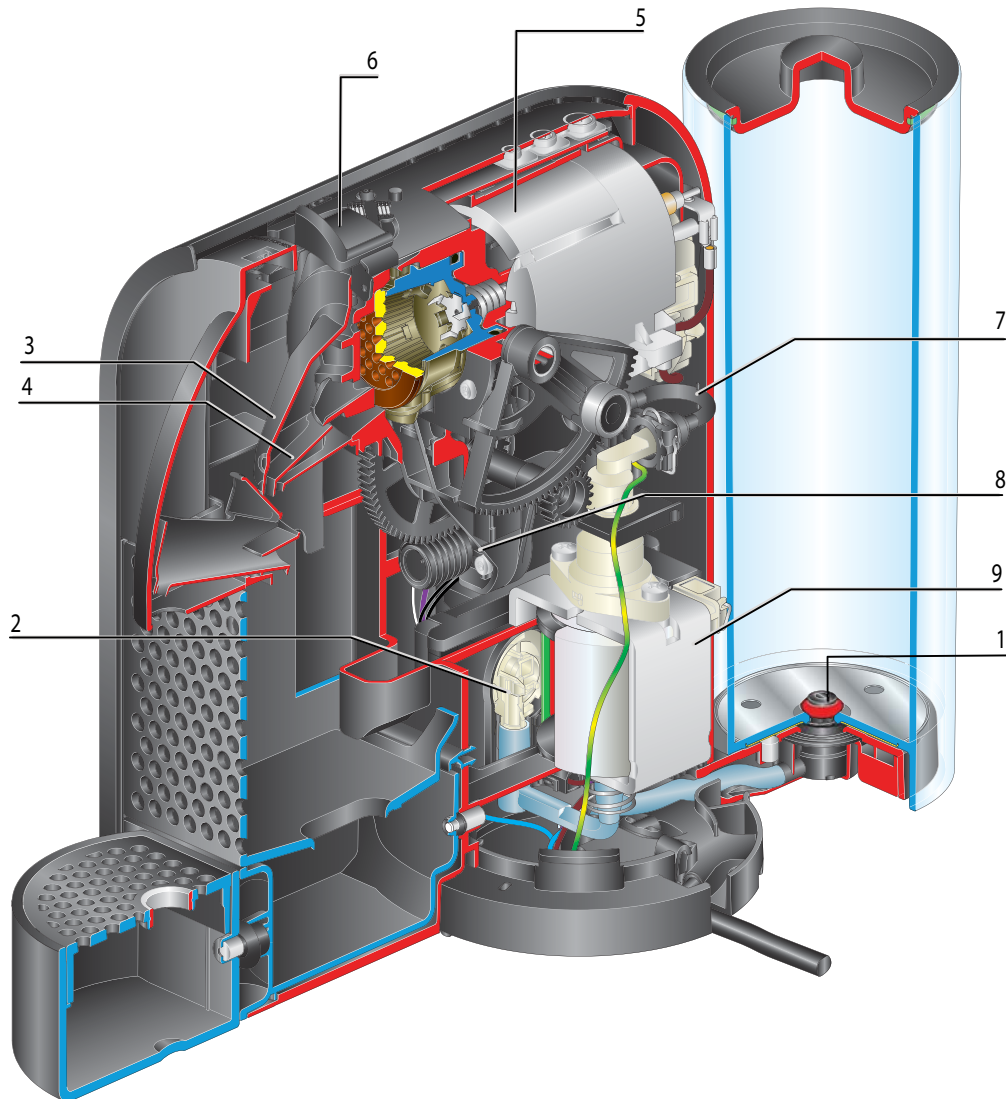

- | | |
|------------------------------------------|----------------------------|
| 1) Low pressure connector for water tank | 6) BU housing |
| 2) Flowmeter | 7) High pressure connector |
| 3) Steam cover | 8) Motor |
| 4) Drop stop | 9) Pump |
| 5) Thermoblock | |



2.3 Fluid system

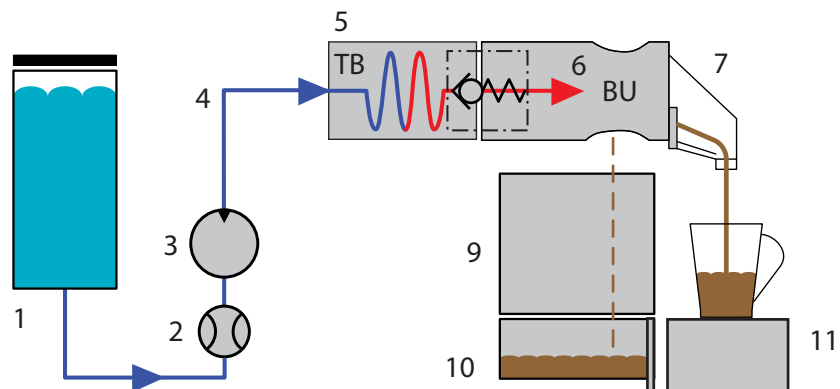
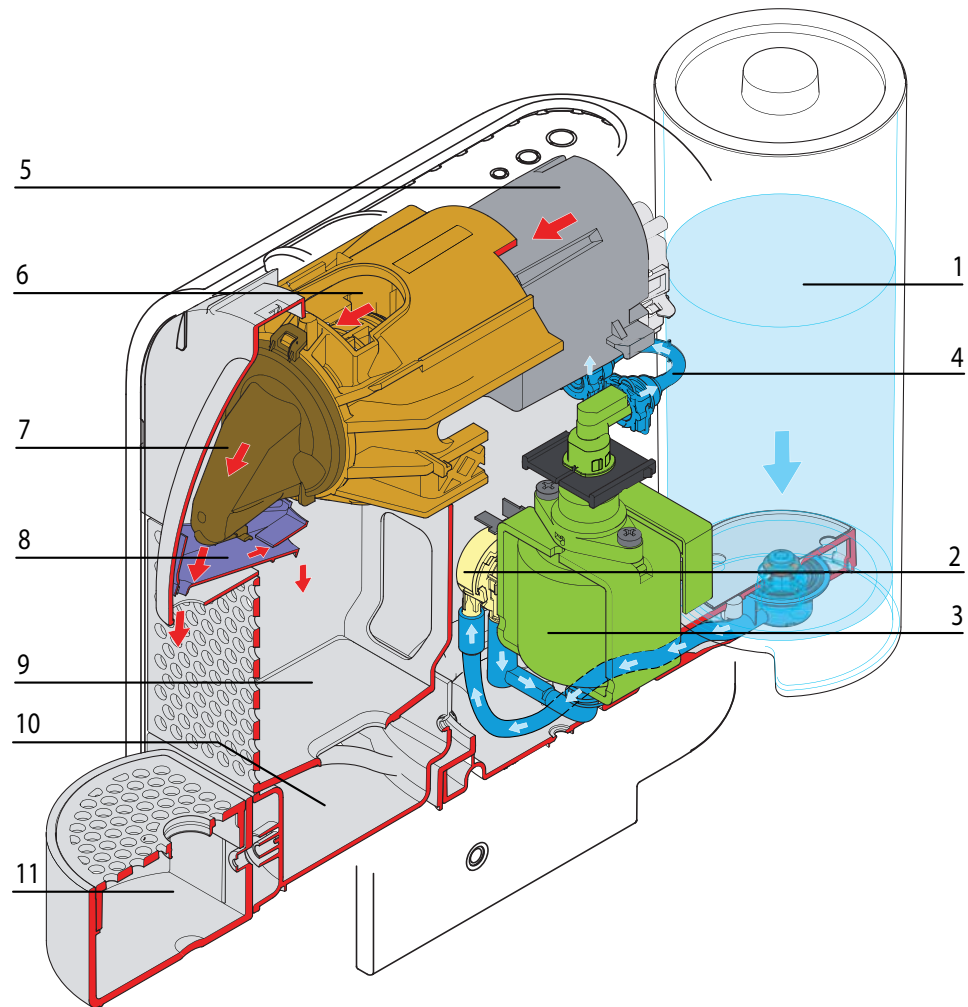

- 1) Water tank
- 2) Flowmeter
- 3) Pump
- 4) High pressure connector
- 5) Thermoblock
- 6) Capsule cage

- 7) Coffee outlet
- 8) Drop stop
- 9) Capsule container
- 10) Drip tray
- 11) Cup support



3 TECHNICAL DATA

3.1 Rating plates

3.1.1 Examples of brand specific rating plates

i The rating plate can be found at the bottom of the coffee machine.

i This overview shows examples of various brands and is subject to alterations.

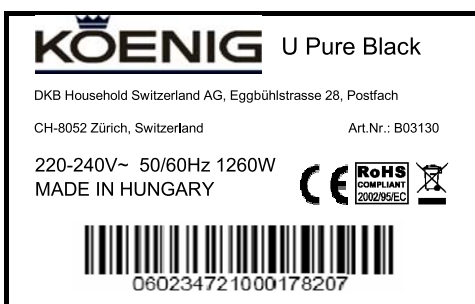
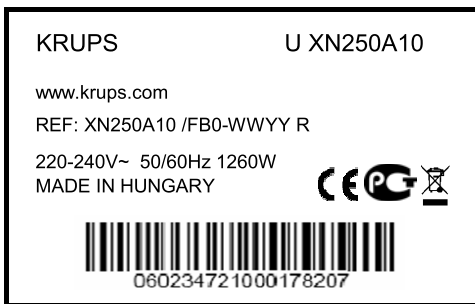



3.1.2 Rating plate details (example)

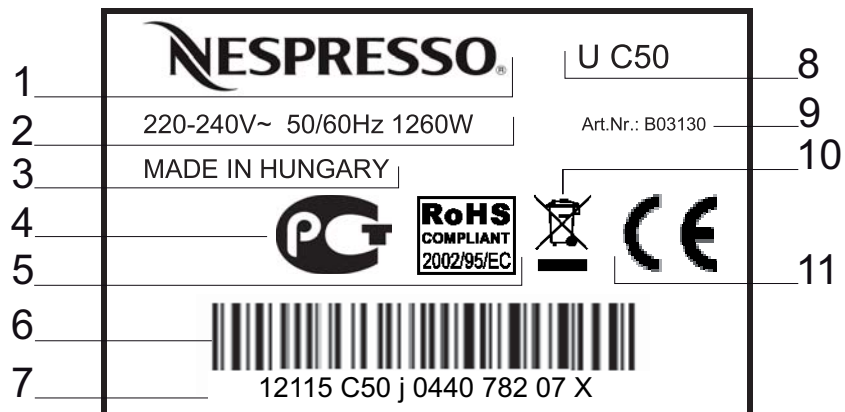

- | | |
|-------------------------------------------------------------|----------------------------------------------------------------|
| 1) Brand name | 7) Serial number |
| 2) Voltage and power rating | 8) Machine type |
| 3) Place of manufacture | 9) Article number of the rating plate |
| 4) National approval sign of Russia (GOST R) | 10) Special disposal icon (do not dispose with ordinary waste) |
| 5) Conformity with RoHS guidelines (lead free solder, etc.) | 11) Sign of conformity (CE) |
| 6) Barcode | |

Decoding the alphanumeric serial number

Example:

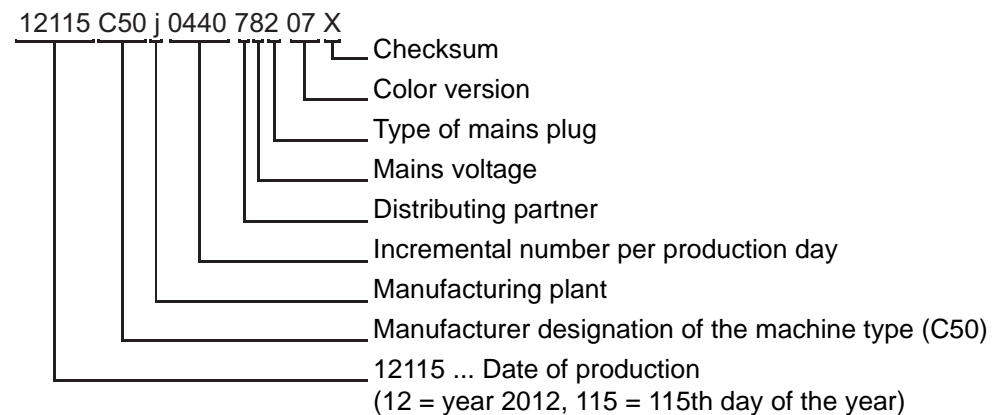

i By decoding the date of production and machine type, the coffee machine can be identified exactly.



3.2 Technical specifications

Mains voltage ranges

- Europe, RU, AU, CN, KR, SG, HK, ME, ZA, IL, BR, AR 220-240 V, 50/60 Hz
- USA, Canada 120 V, 50/60 Hz
- BR, MX 127 V, 50/60 Hz
- Japan 100 V, 50/60 Hz
- Taiwan 110 V, 60 Hz

Approvals

CE, UL "for USA and Canada", PSE, Gost R, Ctick, CCC, KTL, SPRING, SASO, SABS, ISI, IRAM, NOM

EuP standard

The coffee machine is EuP 2013 compliant

Power consumption

- 220-240 V mains voltage approx. 1'260 W
- 100/110/120/127 V mains voltage 1'160 - 1'370 W

Power consumption of coffee machine main components

(for all voltages and frequencies)

- Thermoblock 1'200 W
- Pump 60 W

Energy consumption (CECED / FEA 2009 method)

- Energy efficiency class level A - 40%
- Daily energy consumption 76 Wh
- Annual energy consumption 28 kWh

Pump

Pump pressure

- Max. permissible 20 bar ± 3 bar
- During coffee preparation (depending on the type of coffee) 9 - 16 bar

Capacities

- Water tank approx. 0.8 l
- Tray water capacity min. 100 ml
- Capsule container approx. 10 capsules

i EuP ... Energy using Products

See commission regulation no. 1275/2008 of the European Union.

i Advised water tank capacity to avoid spilling.



TECHNICAL DATA

Volume of prepared coffee

- factory settings

Small cup "Ristretto"	25 ml ($\pm 7\%$)
Small cup "Espresso"	40 ml ($\pm 7\%$)
Large cup "Lungo"	110 ml ($\pm 7\%$)

- customer settings

Programmable setting range	20 - 200 ml
----------------------------------	-------------

Environmental conditions

Operating temperature	+ 5 °C up to + 45 °C (+ 41 °F up to + 113 °F)
Storage temperature.....	- 25 °C up to + 65 °C (- 13 °F up to 149 °F)
Altitude	up to 2'500 m above sea level
Humidity	no restrictions

Various data

Preheating time	approx. 25 sec
Automatic shut off time	after 9 min of non-use
Safety temperature (electronically controlled)	120 °C (248 °F)
Safety temperature (thermal cut-off)	167 °C (333 °F)
Coffee temperature at outlet.....	86 °C \pm 3 °C (187 °F \pm 5,4 °F)
Descaling temperature	setting 70 °C (158 °F)



3.2.1 Dimensions and weight & size

i Dimensions in [mm].

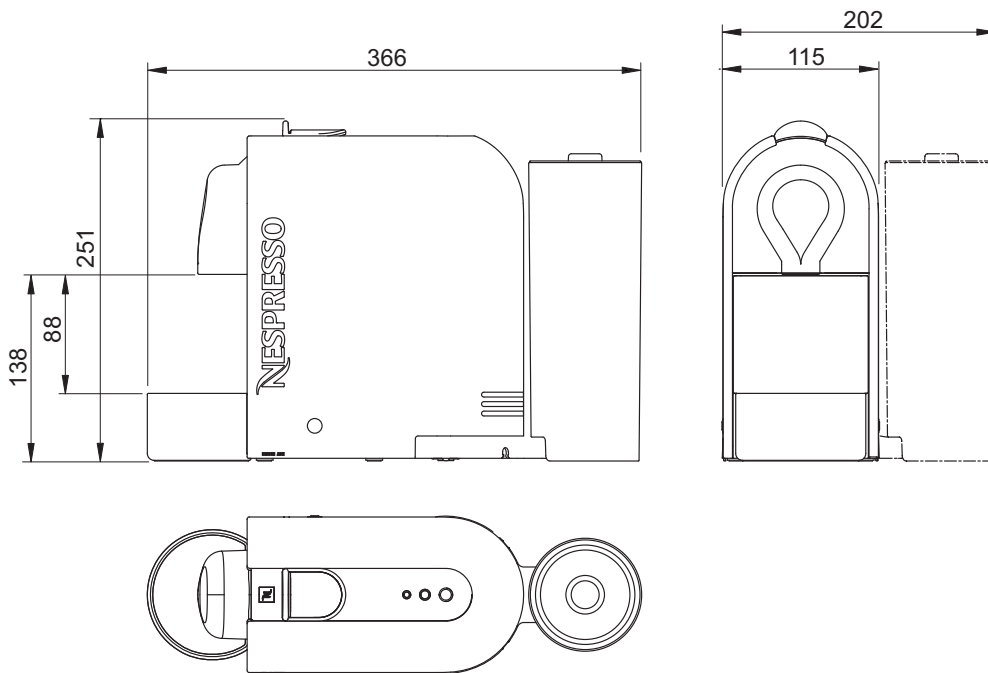

- Dimensions (length x width x height) 366 x 115 x 251 mm
- Distance drip grid - coffee outlet: 88 mm (Espresso mode)
- Distance bottom coffee outlet: 138 mm (Macchiato mode)
- Power cable length min. 0.8 m (depending on national regulations)
- Weight (without water) approx. 3 kg



4 OPERATION

4.1 General information

For an overview of operational controls see “Main components” on page 6.

For basic operation of the machine such as preparing a coffee and other related information, refer to the user manual.

4.2 Status indication

According to the following table the status of the coffee machine is shown by

- 3 capacitive sensors on MMI PCB









Machine status	State events	LED's	Lungo	Espresso	Ristretto
Off	All elements off		off	off	off
Error electronic	All 3 LED's blink together 2Hz, 3 times every 2 sec.		blinking 2Hz, 3 times every 2 sec.	blinking 2Hz, 3 times every 2 sec.	blinking 2Hz, 3 times every 2 sec.
Stuck capsule	All 3 LED's blink alternating in direction front (1st Lungo 0.5 sec, 2nd Espresso 0.5 sec, 3rd Ristretto 0.5 sec)		on 0.5 sec off 1 sec	off 0.5 sec on 0.5 sec off 0.5 sec	off 1 sec on 0.5 sec
No water	All 3 LED's blink alternating in direction back (1st Ristretto 0.5 sec, 2nd Espresso 0.5 sec, 3rd Lungo 0.5 sec)		off 1 sec on 0.5 sec		
Heat up	Blinking 1Hz on most frequently used cup size of the last 10 coffees, Espresso when machine is new. Change to user selection when other capacitive area is touched		Blinking 1Hz or off	Blinking 1Hz or off	Blinking 1Hz or off
Ready	Steady light on most frequently used cup size, Espresso when machine is new; or on user selection when a capacitive area has been touched. Switch to most frequently used cup size after each coffee		Steady or off	Steady or off	Steady or off
Brew Ristretto	Steady on Ristretto		Off	Off	Steady



Machine status	State events	LED's	Lungo	Espresso	Ristretto
Brew Espresso	Steady on Espresso		Off	Steady	Off
Brew Lungo	Steady on Lungo		Steady	Off	Off
4 sec. after brew	Steady on cup size that has been brewed		Steady or off	Steady or off	Steady or off
Rinse	All LED's steady on		Steady	Steady	Steady
Descaling ready	All LED's blinking together 2Hz		Blinking 2Hz	Blinking 2Hz	Blinking 2Hz
Descaling pump on	All LED's blinking together 2Hz		Blinking 2Hz	Blinking 2Hz	Blinking 2Hz
Descaling pump off	All LED's blinking together 2Hz		Blinking 2Hz	Blinking 2Hz	Blinking 2Hz
Emptying & T >115°C	Espresso On 0.5sec (after 6 sec of pressing touch) (confirmation)		off	On 0.5sec	off
Emptying	Lungo and Ristretto blinking together 1Hz		Blinking 1Hz	Off	Blinking 1Hz
Overheat	All blinking together 1Hz		Blinking 1Hz	Blinking 1Hz	Blinking 1Hz
Switch Auto off time after 30min	Espresso On 0.5sec		Off	On 0.5sec	Off
Switch Auto off time after 9 min	Espresso On 3 x 0.5sec		Off	On 0.5sec Off 0.5sec On 0.5sec Off 0.5sec On 0.5sec	Off
Factory setting	Ristretto On 0.5sec		Off	Off	On 0.5sec
Switch to power off	Ristretto, Espresso and Lungo together On 0.5sec		On 0.5sec	On 0.5sec	On 0.5sec



OPERATION

Machine status	State events	LED's	Lungo	Espresso	Ristretto
Programming Lungo	Ristretto & Espresso On 0.5sec (confirmation)	  	Off	On 0.5sec	On 0.5sec
Programming Espresso	Ristretto & Lungo On 0.5sec (confirmation)	  	On 0.5sec	Off	On 0.5sec
Programming Ristretto	Espresso & Lungo On 0.5sec (confirmation)	  	On 0.5sec	On 0.5sec	Off



4.3 Machine modes

This table helps to understand the operating modes of the U coffee machines:

Machine mode	Enter mode	Actions	Exit mode
1 Heat up mode	Every time after switching on machine	Heats up thermoblock to ready temperature 90 °C within 30 sec without overshooting target temperature	e.g. switching off machine
2 Self test mode	Every time after switching on machine	Tests: <ul style="list-style-type: none"> • NTC short circuit • NTC connected • Checks if thermoblock reaches ready temperature within 2 min after switch on 	e.g. switching off machine
3 Ready mode	<ul style="list-style-type: none"> • After heat up and self test mode was ok • After brewing or volume brewing coffee • After reset mode • After leaving descaling mode 	Keeps thermoblock temperature at 90 °C	e.g. switching off machine
4a Brewing mode	Brewing mode: <ul style="list-style-type: none"> • Press and release any coffee button 		<ul style="list-style-type: none"> • Press and release any coffee button when machine is in brewing mode or automatic exit given by the flowmeter
4b Volume brewing mode (programming cup size)	Programming mode: <ul style="list-style-type: none"> • Open the slider • Press and hold any coffee button for more than 3 sec 		<ul style="list-style-type: none"> • Release corresponding coffee button when machine is in programming mode • Switch off machine
5 Descaling mode	<ul style="list-style-type: none"> • Switch on machine, wait until ready • Press and hold the 3 coffee buttons for at least 3 sec 	<ul style="list-style-type: none"> • Regulates temperature to 55 °C (after pump was started) • Stops and starts pump with any coffee button, no volume brewing in descaling mode 	<ul style="list-style-type: none"> • Press and hold the 3 coffee buttons for at least 3 sec <p>Note: When machine is switched off during any descaling mode, then it goes to descaling mode ready state after next switch on</p>



OPERATION

Machine mode	Enter mode	Actions	Exit mode
6 Emptying mode (evaporating)	<ol style="list-style-type: none"> 1) Switch on machine 2) Remove the water tank 3) Open the slider 4) Press and hold the Ristretto and Lungo controls together for at least 6 sec. The other control flashes for confirmation 5) Close the slider to start the procedure 	<ol style="list-style-type: none"> 1) Starts pump 2) Stops pump after 10 sec 3) Heats up thermoblock to 105 °C (100% power) 4) Switches off thermoblock 5) Switches off machine 6) Blocks machine for 10 min 	Switch off machine
7 Resetting mode	<ul style="list-style-type: none"> • Switch on machine • Press and hold the Espresso and Lungo controls together for at least 4 sec. The other control flashes for confirmation 	<ul style="list-style-type: none"> • Resets programmed volumes to factory settings (Ristretto 25ml, Espresso 40ml, Lungo 110ml) • Reset also the automatic off mode to 9 min + the most frequently used cup size to espresso. 	Proceeds with self test mode automatically
8 Auto switch off mode (factory setting of 9 min can be changed to 30 min)	Automatically after a certain period of non-use	<ul style="list-style-type: none"> • Switch off machine after 9 min resp. 30 min if no coffee is brewed or 9 min resp. 30 min after last brewed coffee 	
9 Failure mode	Automatically by following failures: <ol style="list-style-type: none"> a) NTC short circuit b) NTC not connected c) Heat up too slow 	Machine indicates failure with blinking coffee buttons as long as the failure is present	When failure is fixed



4.4 Empty water system

After every operation, some water (max. 25 ml) remains in the coffee machine. Therefore the water system must be emptied

- if the coffee machine will not be used for a long time
- as antifreeze measure
- for repairs and shipment.

i After this procedure, the coffee machine will not be ready for approx. 10 min (until the thermoblock cools to below 100 °C).



- 1) Remove the water tank. Place a container under the coffee outlet.



- 2) Open slider
- 3) Press and hold the Ristretto & Lungo controls together for at least 6 sec. The other control flash for confirmation. Then close the slider to start procedure.



- 4) Machines turns to Off mode automatically when empty.



5 MAINTENANCE

5.1 Descaling



Only use *Nespresso* descaler (5034) or *Nespresso* descaling kit (3035/CBU-2) – never use vinegar!
 Descaler can damage casing and surfaces.
 Immediately clean drops of descaling solution.

5.1.1 Descaling procedure

Need to descale depending on water hardness:

soft: 0-17fH / 0-9dH = descale after 4'000 cups

medium: 18-35fH / 10-19 dH = descale 2'000 cups

hard: over 36fH / over 20dH = descale after 1'000 cups

i Duration approximately 15 minutes

! Observe the safety instructions on the descaler package.

i Use a container with a capacity of min. 1 l.

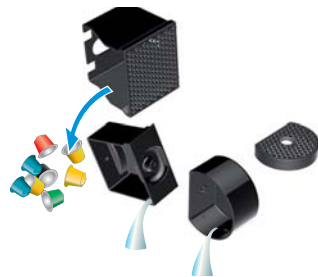

1) Empty the drip tray and the used capsule container.



2) Fill the water tank with 1 unit of *Nespresso* descaling liquid and add 0.5 L / 17 oz of water.



3) Place a container (minimum volume: 0.6 L / 20 oz) under the coffee outlet.



4) Activate the machine by either pushing the slider or one of the cup selection touches



5) Blinking light: heating up.

6) Steady light: ready



7) To enter the descaling mode, push all the 3 controls simultaneously for at least 3sec. A short beep will confirm this. The control area will start blinking.



8) If slider is closed, push any control to start descaling. If slider is open, close it to start descaling. Machine stops when water tank is empty.



9) Refill the water tank with the used descaling solution collected in the container and touch any control to repeat the procedure.



10) Empty and rinse the water tank, capsule container, drip tray and cup support thoroughly. Fill water tank with potable water.



11) When ready, touch any control to rinse the machine. Machine will stop when done.

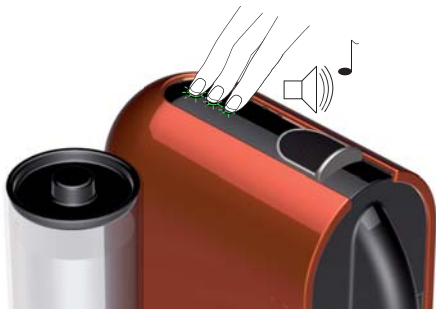

12) To exit the descaling mode, push all the 3 controls simultaneously for at least 3sec. A short beep will confirm this. The machine is now ready for use



5.2 Cleaning procedure



Risk of fatal electrical shock and fire!

Never clean wet or immerse plug, cord or appliance in any fluid. Unplug appliance and let it cool down to avoid burns.

i Never use brushes and/or cleaning agents that contain aggressive or chemical components resp. solvents. Do not put any part in a dishwasher. Use only a damp cloth or sponge and a mild cleaning agent if necessary

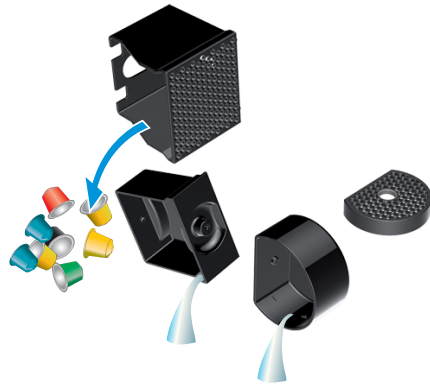

1) Do not use any strong or abrasive cleaning agent or solvent cleaner. Do not put in a dishwasher.

2) Never immerse the appliance or part of it in water.

i Do not use a brush - the water tank can be scratched.



3) Clean the coffee outlet regularly with a damp cloth.



6 TROUBLESHOOTING

6.1 Check list

Check	Error symptoms	Measure / repair work	Further measures / repair work
1 Check the coffee machine for visible damage	1.1 Housing parts broken or damaged	YES - replace housing parts if necessary NO - continue	
	1.2 Power cord damaged	YES - replace power cord NO - connect power cord of machine to the mains and continue	
2 Check mechanical components	2.1 Cup support with capsule and waste water container does not remain in fitting position	YES - check if waste water container has its metallic plate for magnetic mounting NO - continue	NO - replace waste water container.
	2.2 Slider malfunction	YES - slider does not close or close properly NO - continue	YES - Empty the capsule container YES - Check that no capsule is blocked inside the machine NO - replace slider unit
	2.3 Capsule is not ejected correctly	YES - replace brewing unit NO - continue	
3 Fill water tank	3.1 Water tank leaks	YES - replace water tank NO - continue	
4 Move Machine to power on to perform automatic self test	4.1 Coffee machine is not working (does not function)	a) YES - power cord is okay (loose connection)	YES - continue NO - replace power cord
		b) YES - On/Off switch has typical switching noise	YES - continue NO - replace functional block
		c) YES - pump works (press a coffee button)	YES - continue with point e) NO - continue with point d)
		d) YES - both coffee buttons are working	YES - replace pump NO - replace functional block
		e) YES - fine wire fuses or triac on thermoblock defective	YES - replace thermoblock NO - continue
		f) YES - wiring is okay NO - continue with point 4.2	YES - replace functional block NO - replace defective cables
	4.2 Both coffee buttons are blinking 3x fast	YES - thermoblock is hot NO - self test ok - continue	YES - switch off/on coffee machine and check again NO - replace thermoblock or functional block
5 Rinse coffee machine	5.1 No water at coffee outlet	YES - a) water system is empty	YES - fill the water system NO - continue
		YES - b) coffee machine is calcified NO - continue	YES - descale coffee machine (see page 20)
		YES - c) pyramide plate blocked	YES - replace brewing unit NO - continue
		YES - d) flowmeter blocked	YES - clean or replace flowmeter NO - continue
		YES - e) pump cannot produce sufficient water pressure	YES - replace pump NO - continue

i After an initial inspection in accordance with this check list, errors are quickly found and corrected with the appropriate measure. Therefore, adhere to the sequence of the check list. Repair every occurring error and work the check list through until it is completed.



TROUBLESHOOTING

Check	Error symptoms	Measure / repair work	Further measures / repair work
6 Measure coffee temperature during coffee preparation (see page 47)	6.1 Temperature is too low (below 83°C)	YES - descale coffee machine (see page 20) NO - continue	
	6.2 Temperature too high (over 89 °C)	YES - replace thermoblock NO - continue	
7 Check for leakage and sufficient flow rate	7.1 Hose connections leak	YES - replace high pressure connector NO - continue	
	7.2 Brewing unit leaks	YES - replace brewing unit NO - continue	
	7.3 Rate of flow not within standard range (60-120ml in 30 sec)	YES - coffee machine is calcified NO - continue with point 9	YES - descale coffee machine (see page 20) NO - replace pump
8 Descale coffee machine (if necessary)	8.1 Coffee machine is calcified	YES - descale coffee machine (see page 20) NO - continue with point 9	
9 Check water tank contents after descaling and rinsing	9.1 Particles of calcium and rust visible in water	YES - descale and rinse coffee machine again to clean water circuit (see page 20) NO - continue	YES - inform customer to descale coffee machine periodically and to use the specified descaling product only.
10 Final cleaning (see page 22)		No errors found according to check list?	YES - for more information please contact <i>Nespresso</i> Service Division
End of check list			



7 REPAIRS

These repair instructions

- are based on exploded drawings with position numbers combined with repair and mounting tips,
- presuppose basic knowledge in repairing *Nespresso* coffee machines.

7.1 Safety instructions



Risk of fatal electrical shock!
Mains voltage inside the coffee machine.
Disconnect the mains plug before disassembly - the coffee machine must be free of voltage.



Danger of burns!
Hot parts and water under pressure inside the coffee machine (thermoblock in particular).
Let coffee machine cool down before disassembly.



Only use original spare parts from your official supplier for maintenance and repair work.

7.2 Repair and mounting tips

These general advices are completed with specific repair tips in this chapter.

Additional information

For components not mentioned in this repair chapter, refer to the chapters "Explosion drawings" on page 55 and "Parts list" on page 57.

Snap connections

Parts of the case and components of the coffee machine are connected screwless with latches.

-  **When loosening these latches, proceed with care and patience to avoid causing any damage.**

Designation of spare parts

The components in the following illustrations are indexed with position numbers. See separate spare parts list for corresponding spare part numbers.

Electrostatic discharge (ESD) protection

The service technician must observe basic ESD protection measures when installing a new electronic component.

 Position numbers are subject to change without notice. For spare part orders, please check current spare part drawings in EF webshop



Wiring arrangement

Random changes in the wiring arrangement of the wired model version during a repair can cause

- electromagnetic interferences,
- squeezed wires,
- insulation defects due to contact with hot parts,
- insulation problems if low and high voltage wires are not separated,
- damage to the functional block.

Protective measures:

- Do not change the thermoblock wiring (thermo fuses and NTC sensor).
- Refer to wiring diagram when reconnecting cables and wires.

Residual water

- If it is necessary to pull off hoses, hold ready a small receptacle and a towel to collect and wipe away leaking water.
- A special procedure is necessary to empty the fluid system of the coffee machine for repair or shipment (refer to "Empty water system" on page 19).

7.3 Tools and accessories

With the following assortment of tools, all repairs described can be made:

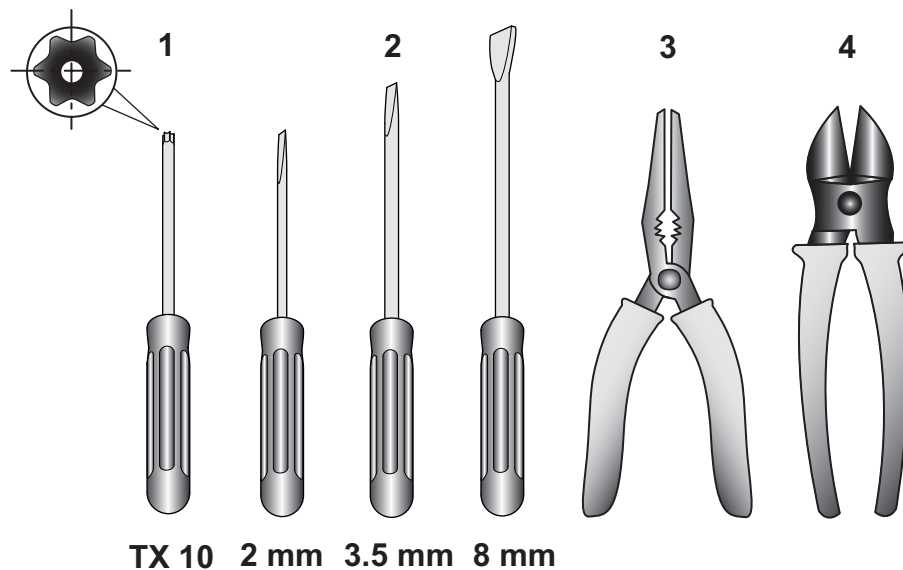
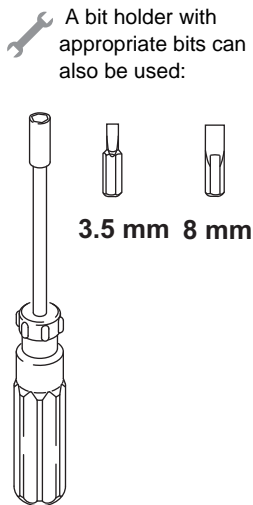

- | | |
|-------------------------------|--------------------------------------------------------------|
| 1) Torx screwdriver TX10 - 70 | 3) Pointed pliers |
| 2) Flat blade screwdrivers: | 4) Side cutting pliers |
| size blade width | 5) Receptacle and towel to catch and wipe away leaking water |
| 00 2 mm | |
| 01 3,5 mm | |
| 05 8 mm | |



7.4 General disassembly

This subchapter shows

- how to replace the power cord,
- all necessary disassembly steps to gain access to the main assembly (brewing unit, thermoblock, hydraulic unit and functional block).

7.4.1 Prepare coffee machine for disassembly



- 1. Check and remove any capsule from the brewing unit. Close the slider.
- 2. Empty water system if hoses have to be detached for repair (see "Empty water system" on page 19).
- 3. Disconnect power plug and let coffee machine cool down.
- 4. Remove all detachable parts from coffee machine:
Cup support, drip grid, capsule container, drip tray, water tank with lid.



7.4.2 Remove cover

i Use a wrap foil to protect the cover during service.

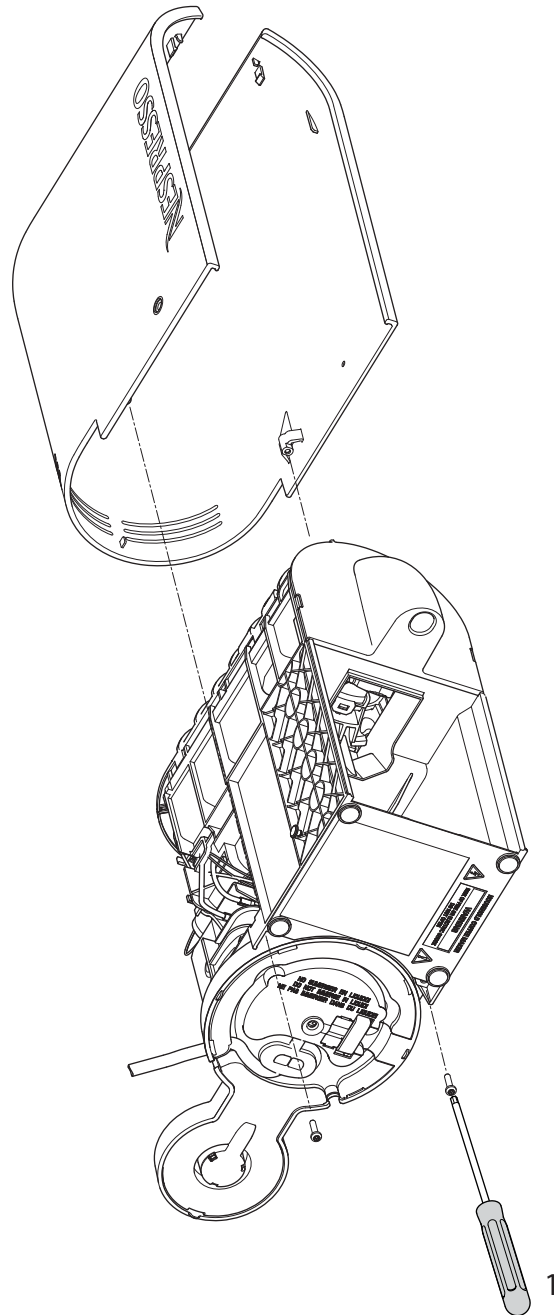

i Take care not to scratch the surface and keep the cover at a safe place.

- Loosen 2 screws on the machine floor (1).
- Remove the cover by hand.



7.4.3 Remove front cover and drop stop

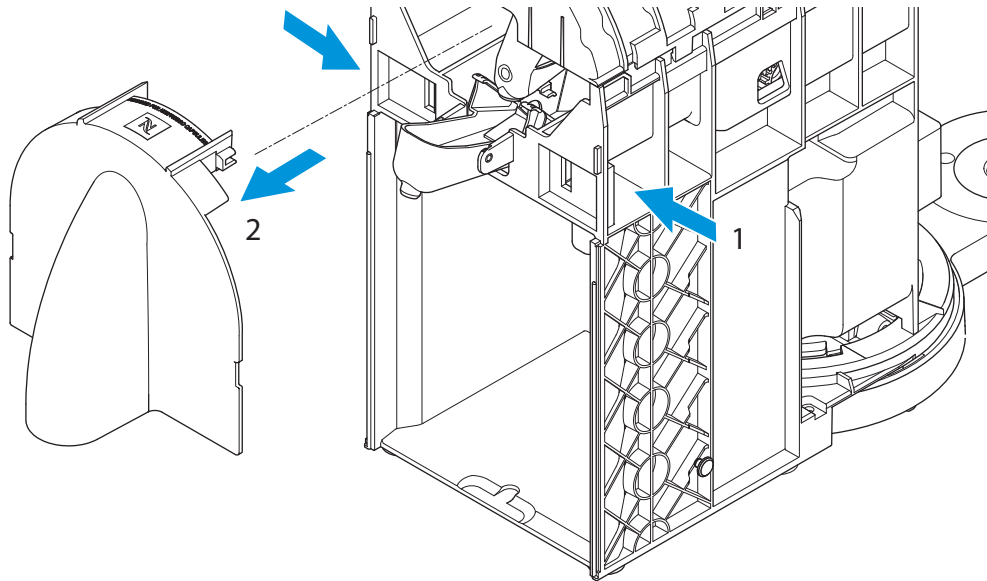

- Dismantle the front cover clips by hand (1).
- Remove front cover (2).

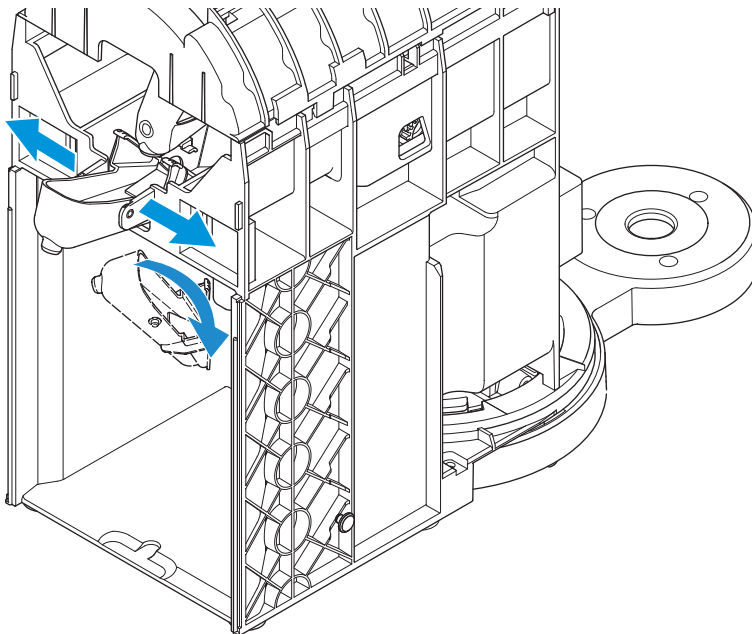

- Dismantle the drop stop clips by hand.
- Remove the drop stop.

i To dismantle the drop stop, the brewing unit must be closed.

 Use a cordless drill driver connected to the motor to close the unit or, before dismantling the machine, start a coffee without a capsule and remove the power plug during extraction.



7.4.4 Remove slider chassis and slider unit

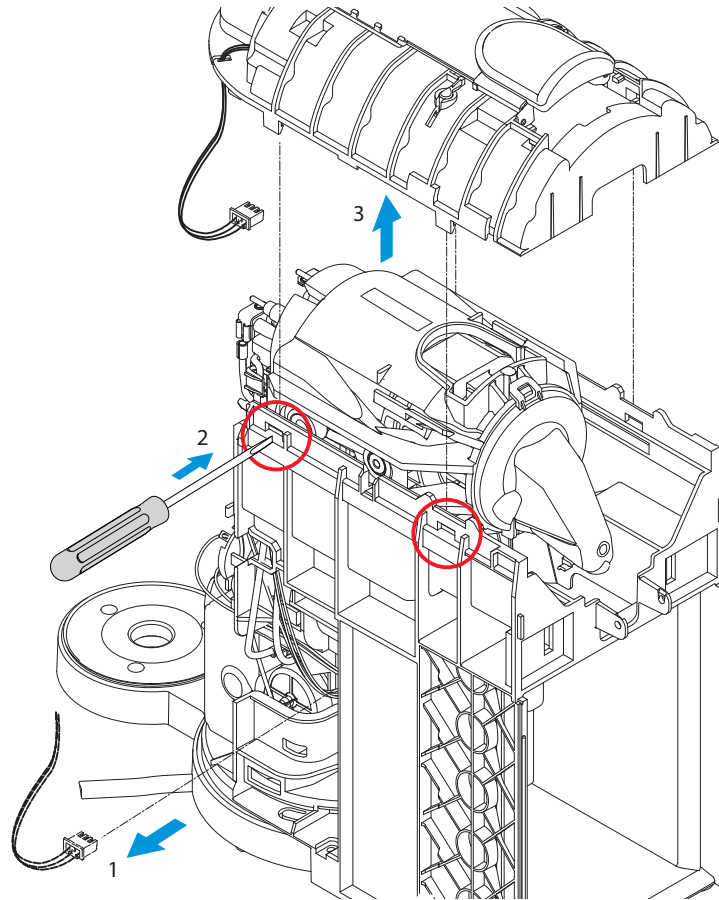

- Plug out the touch pad cable (1)
- Dismantle the slider-chassis clips with a screwdriver (2).
- Remove the slider chassis

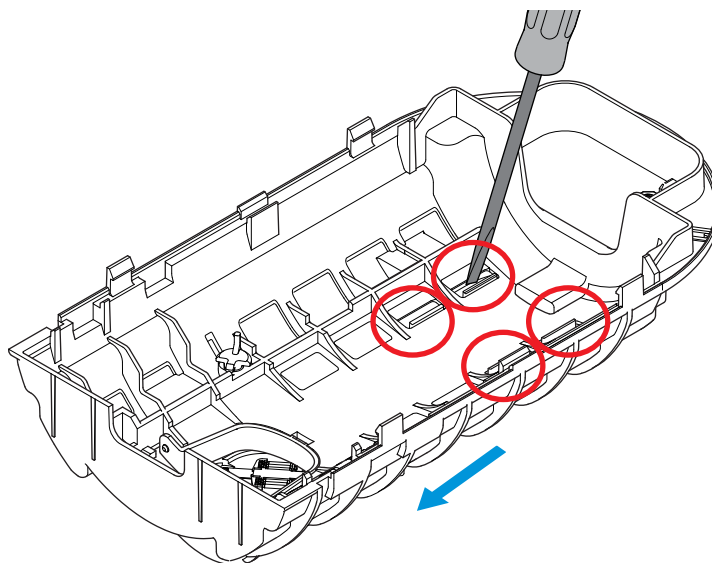

- Pull down the blind (slider) during the dismantling of the clips.

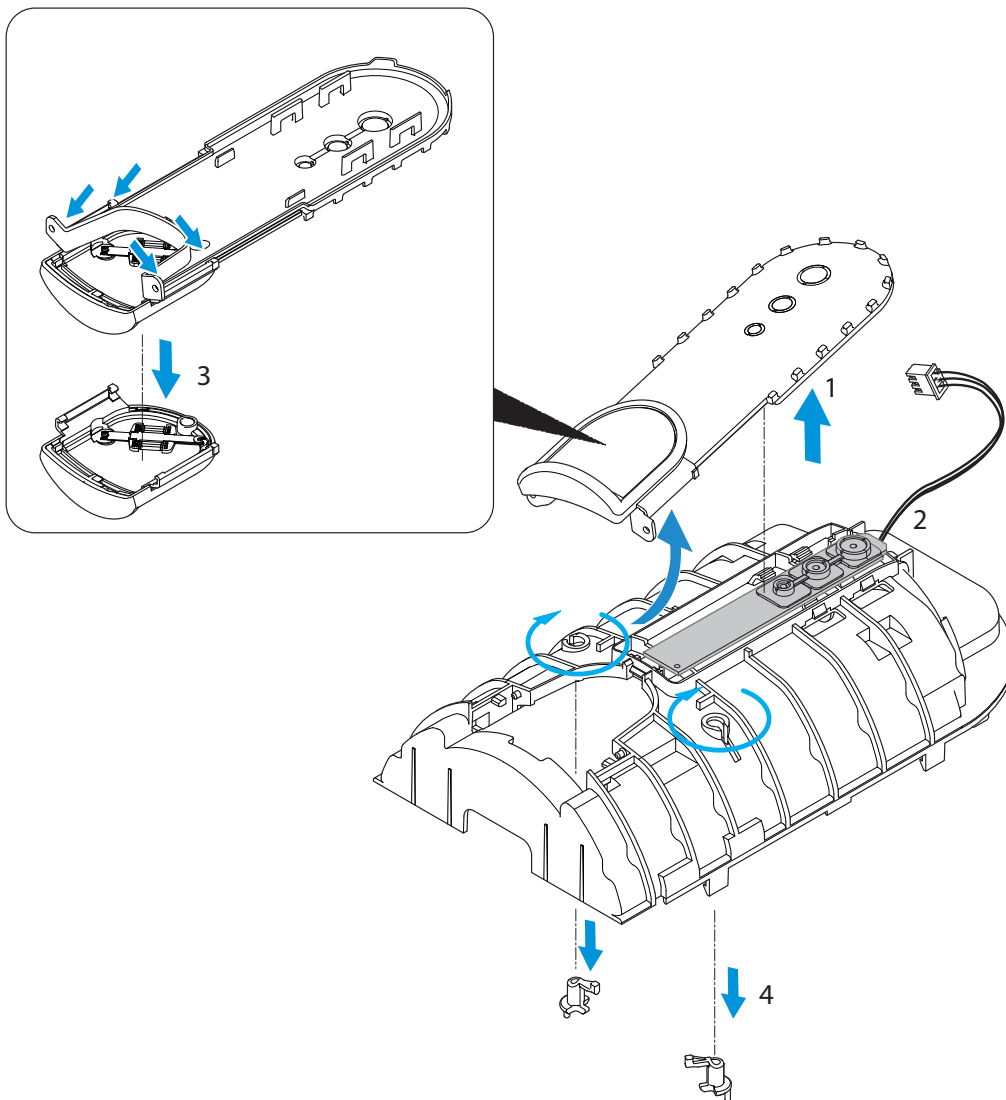

- Remove slider unit (1): press forward and upward.
- Remove touch pad cable (2).
- Remove touch pad (2).
- Dismantle slider for removing spring packet (3).
- Remove the ratchets (4).

Assembly checkpoint

Position the slider and spring packet befor assembly slider-unit.

Position the ratchets and touch pad cable befor assembly slider-chassis.



7.4.5 Remove pivot bottom, cable bracket, power cable

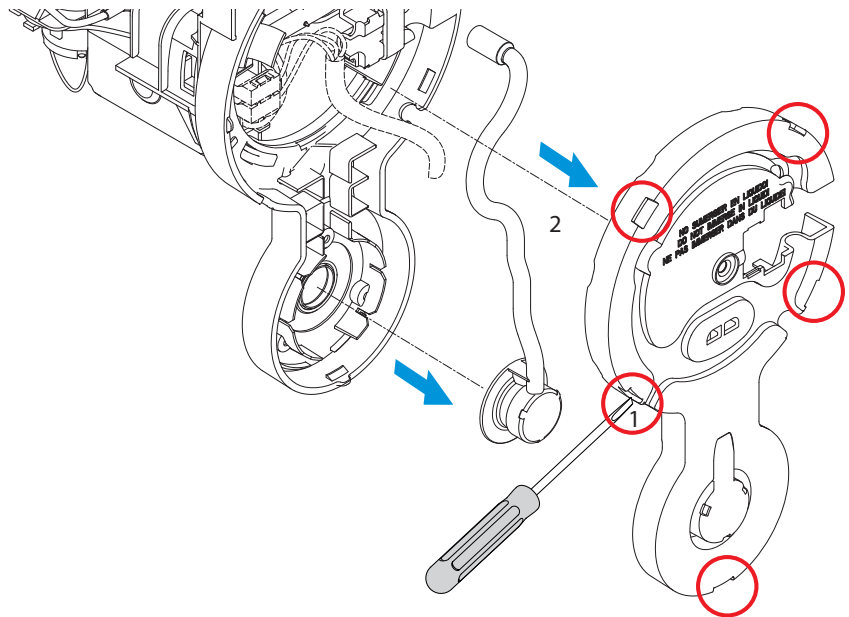

- Dismantle the clips with a screwdriver (1)
- Remove the pivot bottom and low pressure connector WT (2).

 The strain cable bracket is under tension. Therefore, hold down the strain relief clamp with your finger when unlatching it.

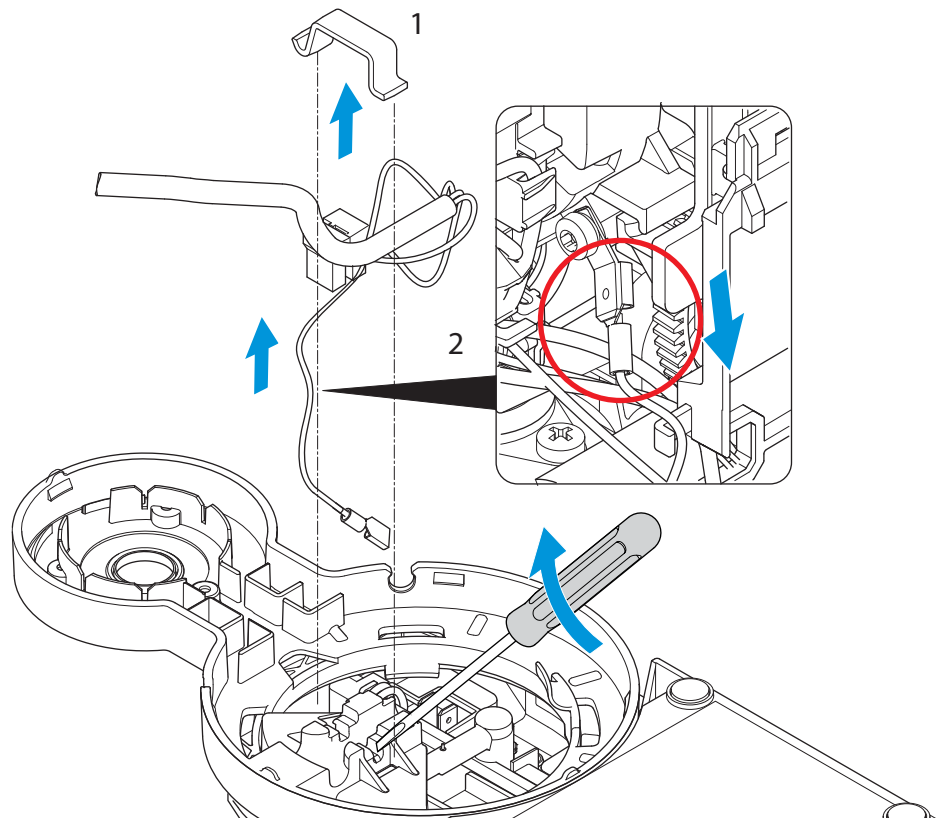

- Remove the cable bracket (1) with a screwdriver and the connection cable (2).

Assembly checkpoint

- Never re-use damaged cables.



7.4.6 Remove electronic device

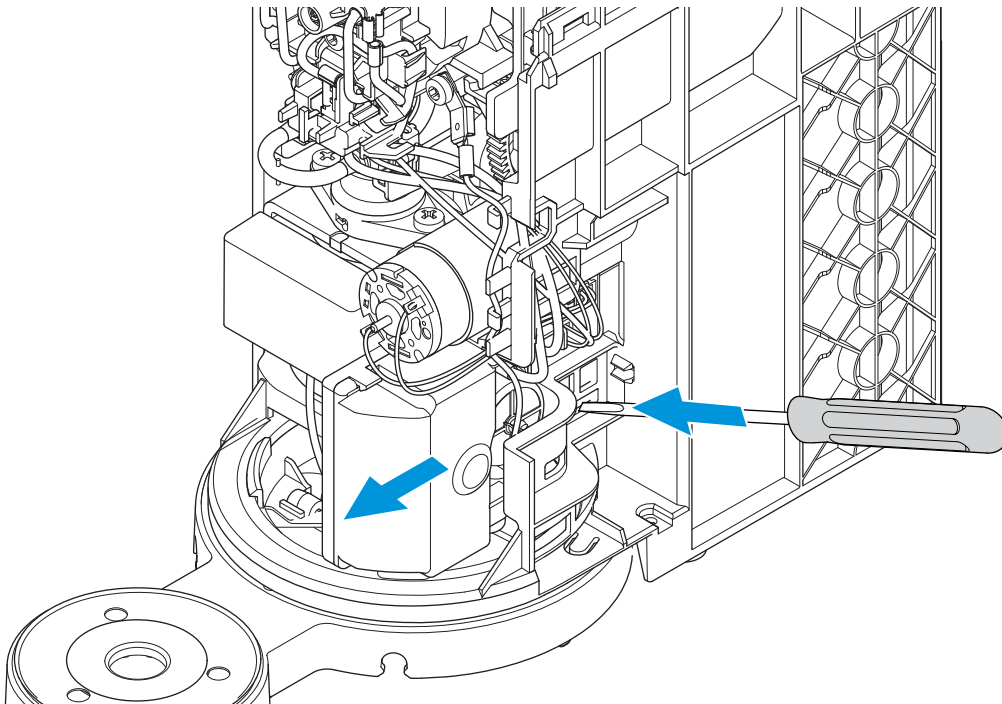

- Dismantle the electronic device clip with a screwdriver.
- Unplug cables and remove electronic device.

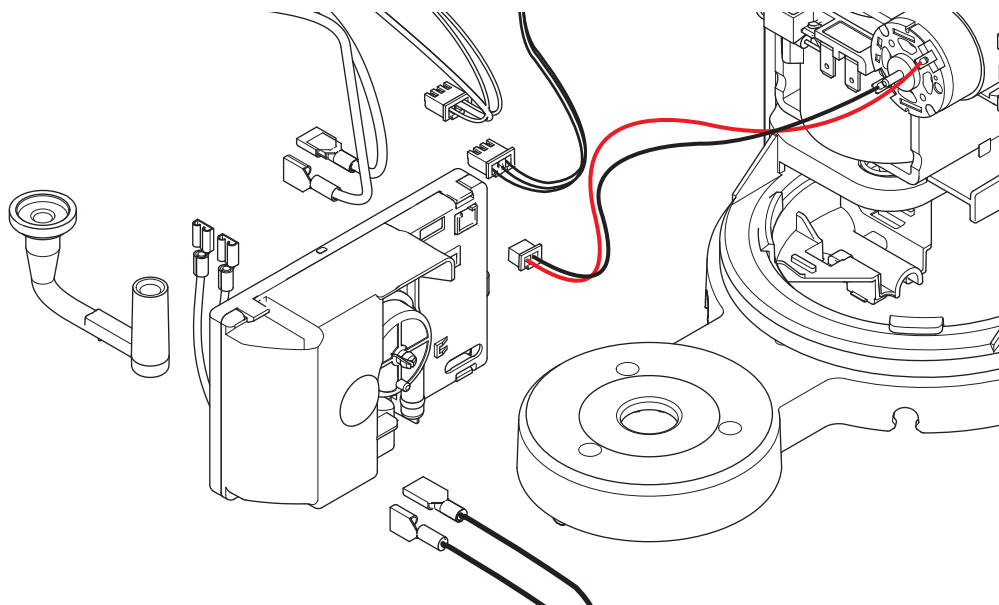

- Remove pump isolation.
- Plug out low pressure connector pump, pump cables, Motor cables, NTC / Triac signal cables - XHP 3 connector, triac power cable and STB cable.

Assembly checkpoint

Never re-use damaged cables.



7.4.7 Remove flowmeter (FM) PCB

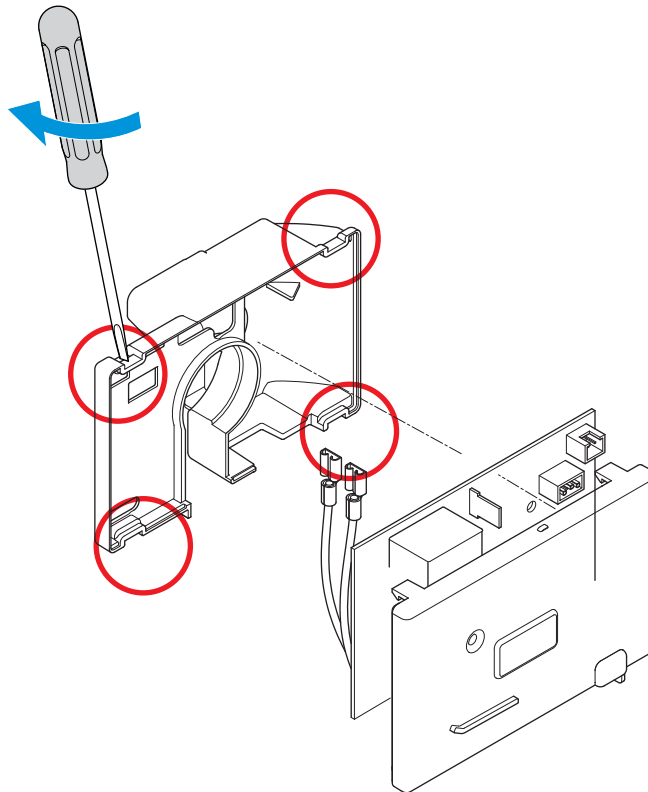

- Dismantle the electronic device clips with a screwdriver.

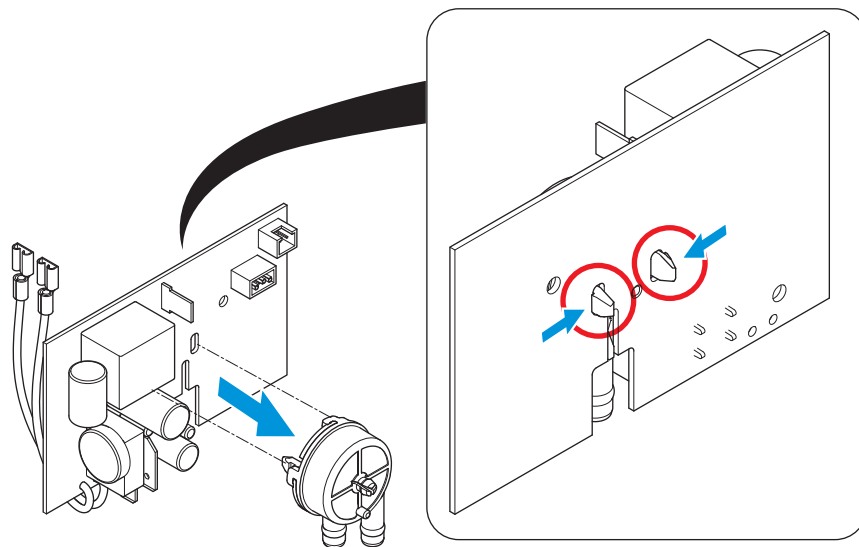

 Latch will break if not handled carefully!

- Dismantle the flowmeter clips by hand and remove flowmeter

Assembly checkpoint

Never re-use a dismantled flowmeter. Assemble a new flowmeter.



7.4.8 Remove high pressure connector

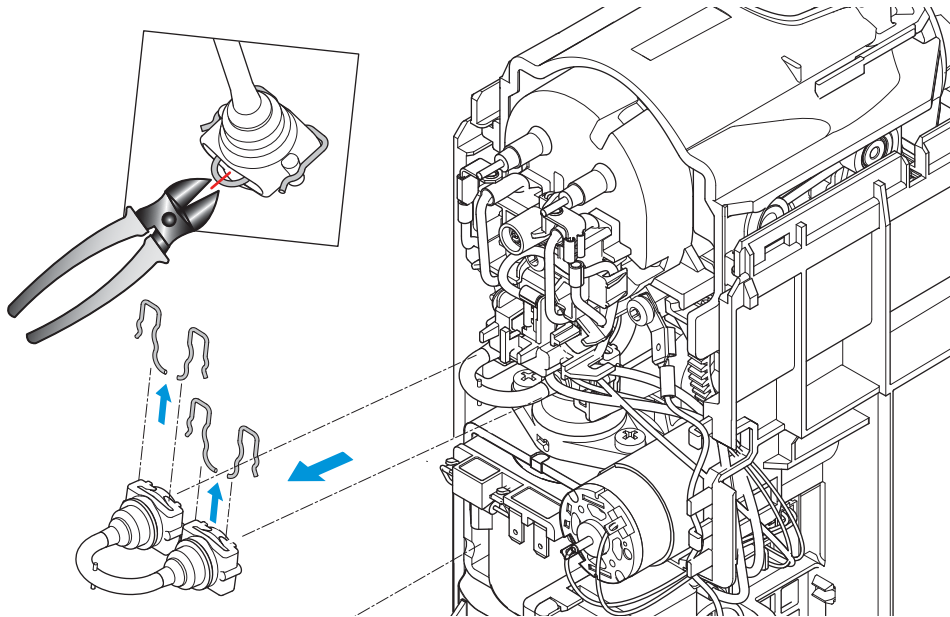

- Remove the high pressure connector by cutting the connector clips.

7.4.9 Remove pump

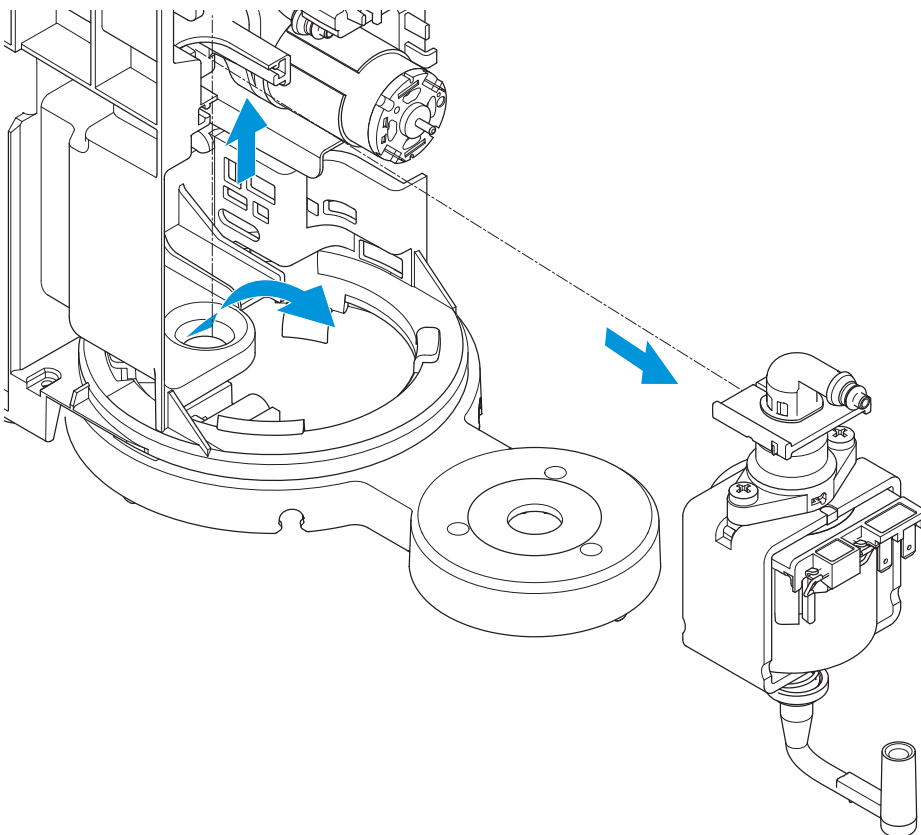

- Remove pump support
- Remove pump.



7.4.10 Remove brewing unit device and steam cover

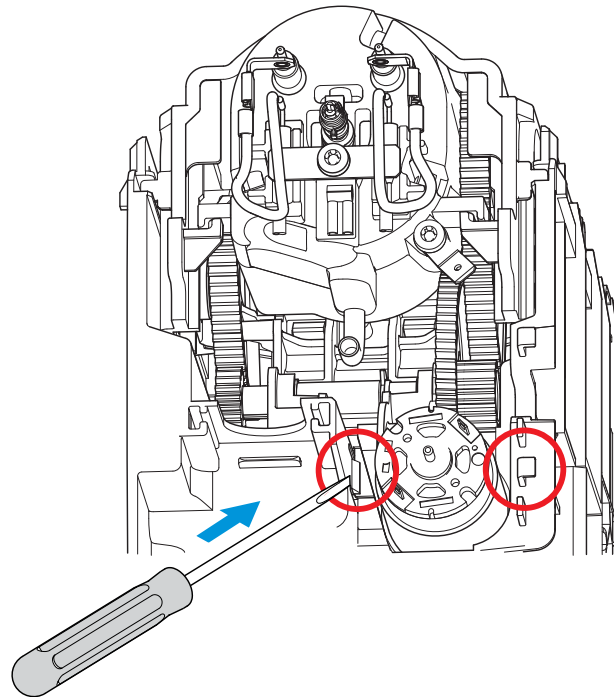

- Dismantle the brewing unit device clips with a screwdriver.

i Push the thermoblock to the backside and upward at the same time.

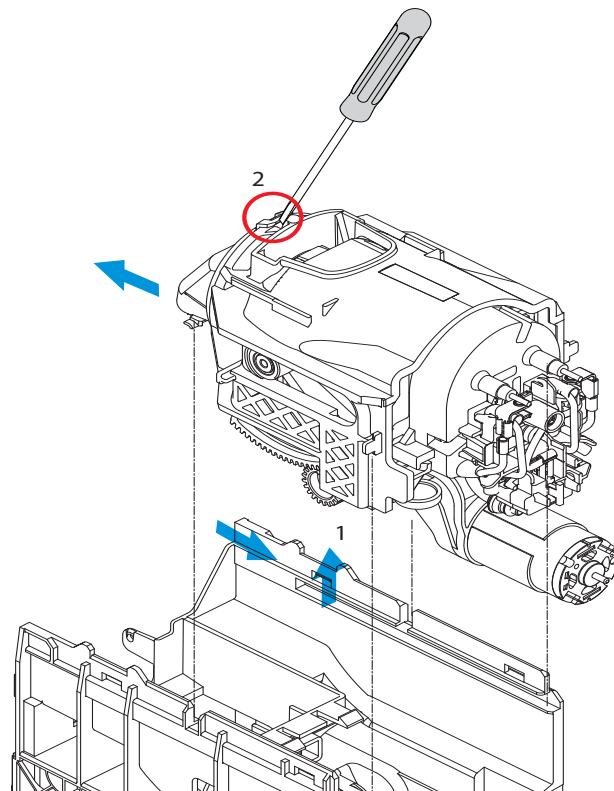

- Remove brewing unit.
- Dismantle the steam cover clips with a screwdriver and remove steam cover.



7.4.11 Remove BU housing and gear wheels

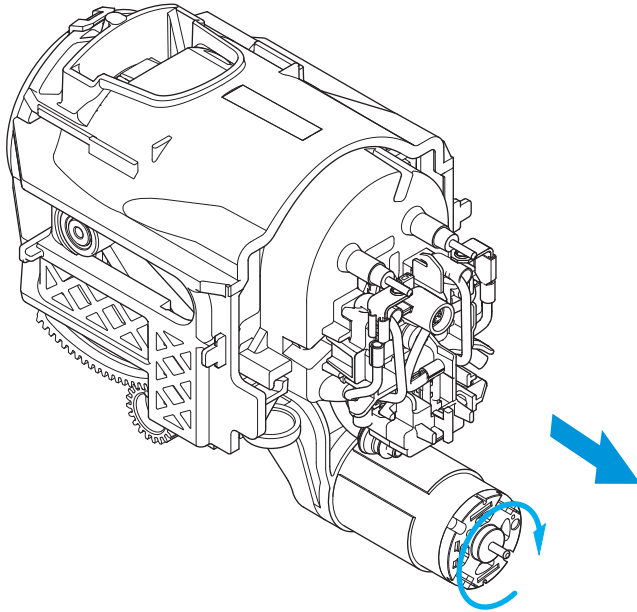

- Turn worm gear till the stop limit.

 Use e.g. a cordless drill driver.

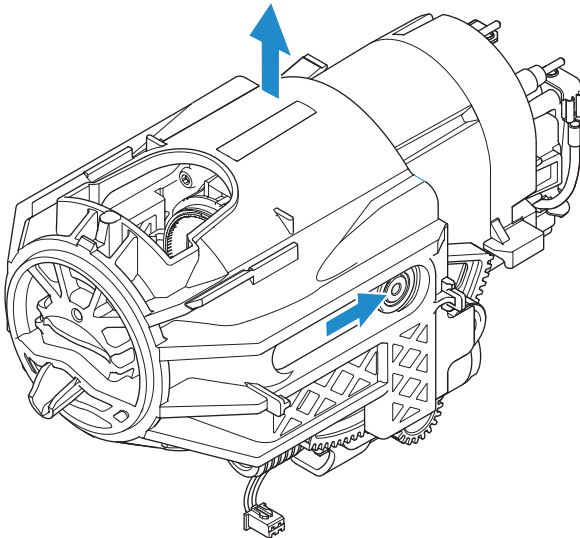

- Lift up the cover once the guides are at the rear, vertically positioned.

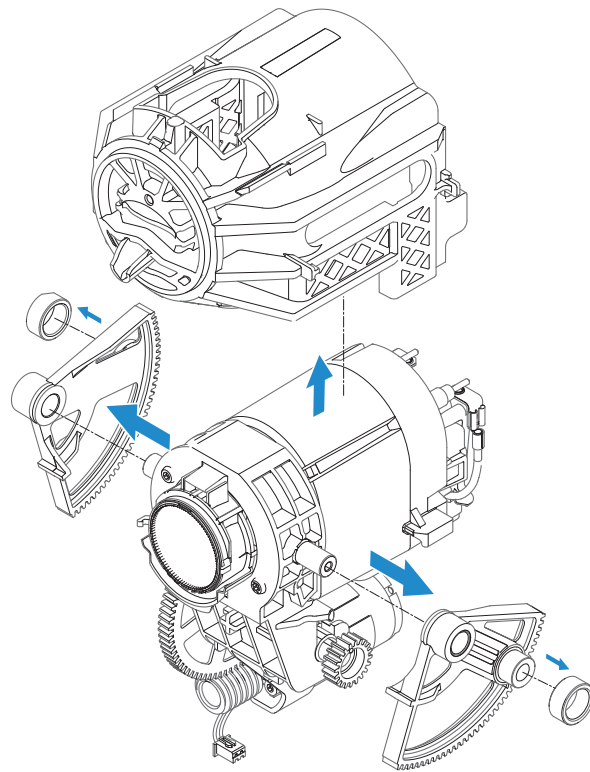

- Remove BU housing, bush bearing, gear lever right, gear lever left.

Assembly checkpoint



left side not ok



left side ok



left side not ok

- Note the correct mounting position for gear lever left (41) and gear lever right (47).



7.4.12 Remove thermoblock and capsule cage

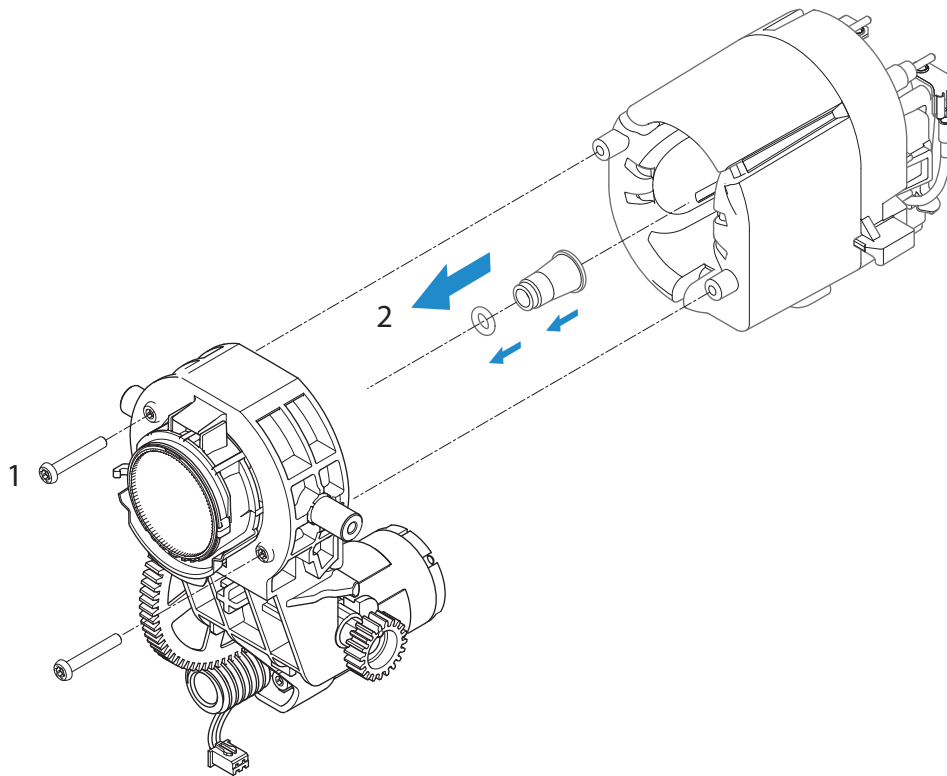

- Loosen 2 screws to remove thermoblock and capsule cage.
- Remove TB sleeve and o-ring seal tb tube.



7.5 Wiring diagrams

7.5.1 Wiring diagram 220 V - 240 V IEC

i Depending on national regulations, one or two fine wire fuses are mounted on the thermoblock.

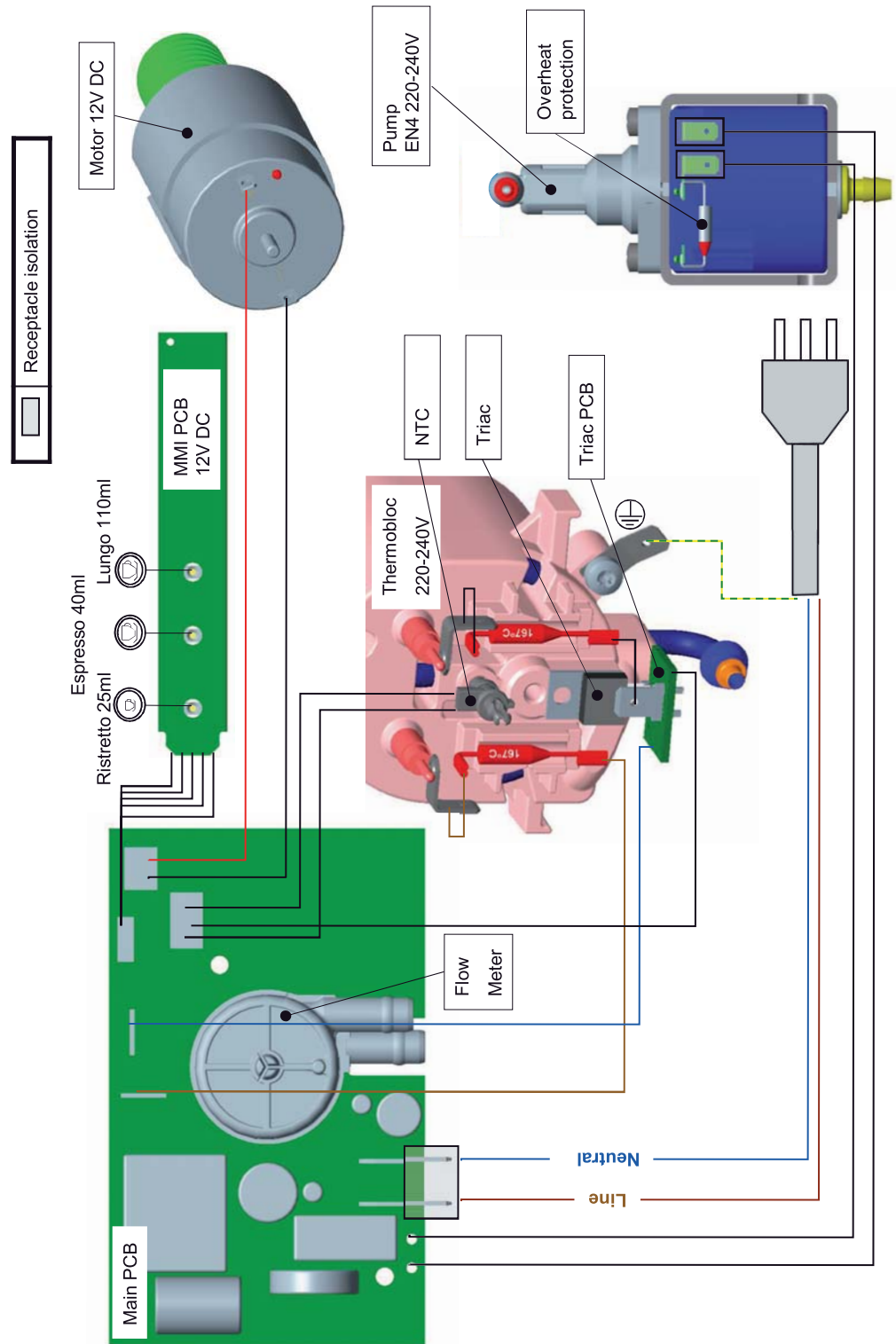



7.5.2 Wiring diagram 120 V UL (USA / Canada)

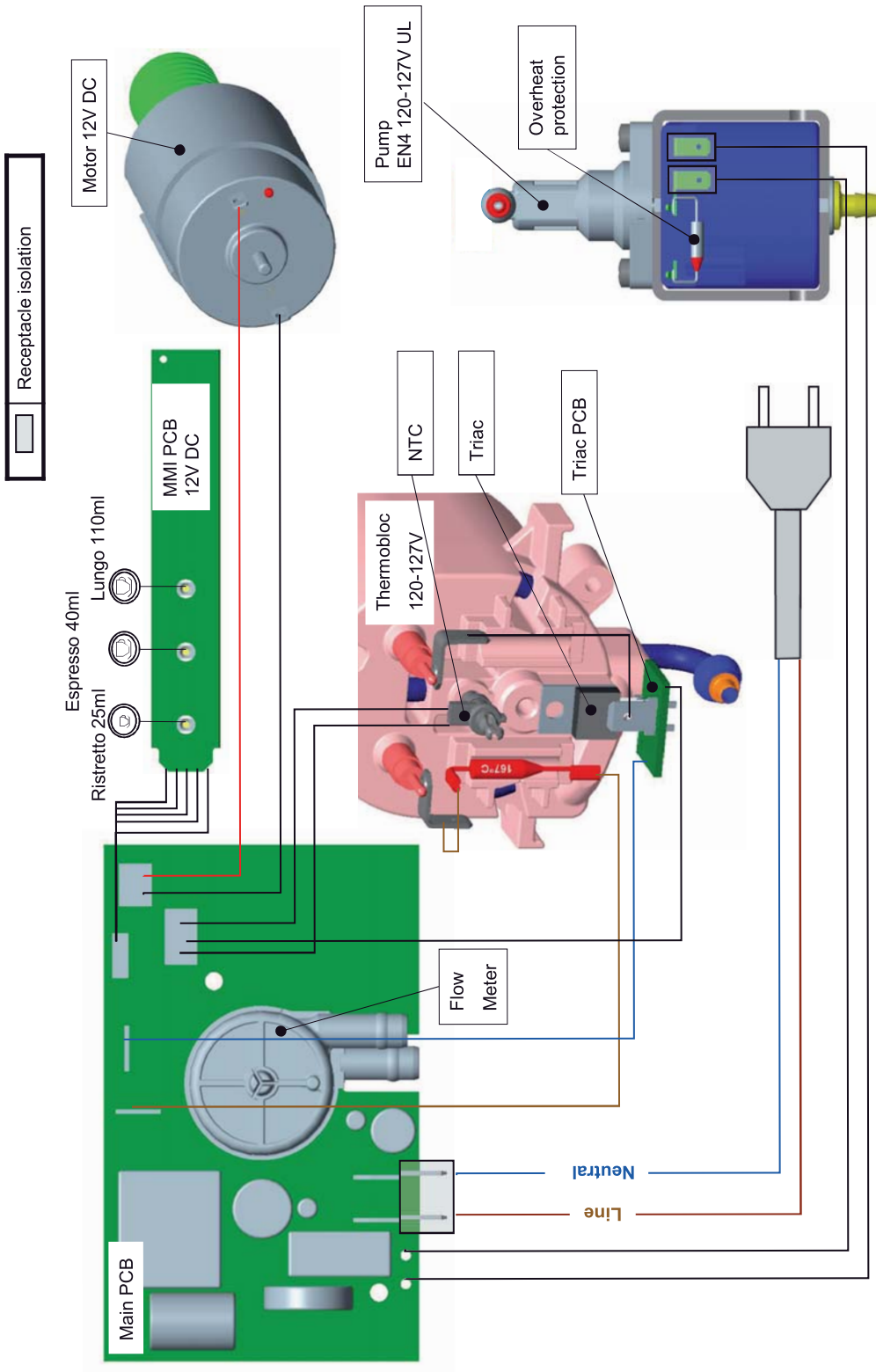



7.5.3 Wiring diagram 127 V IEC (Brazil)

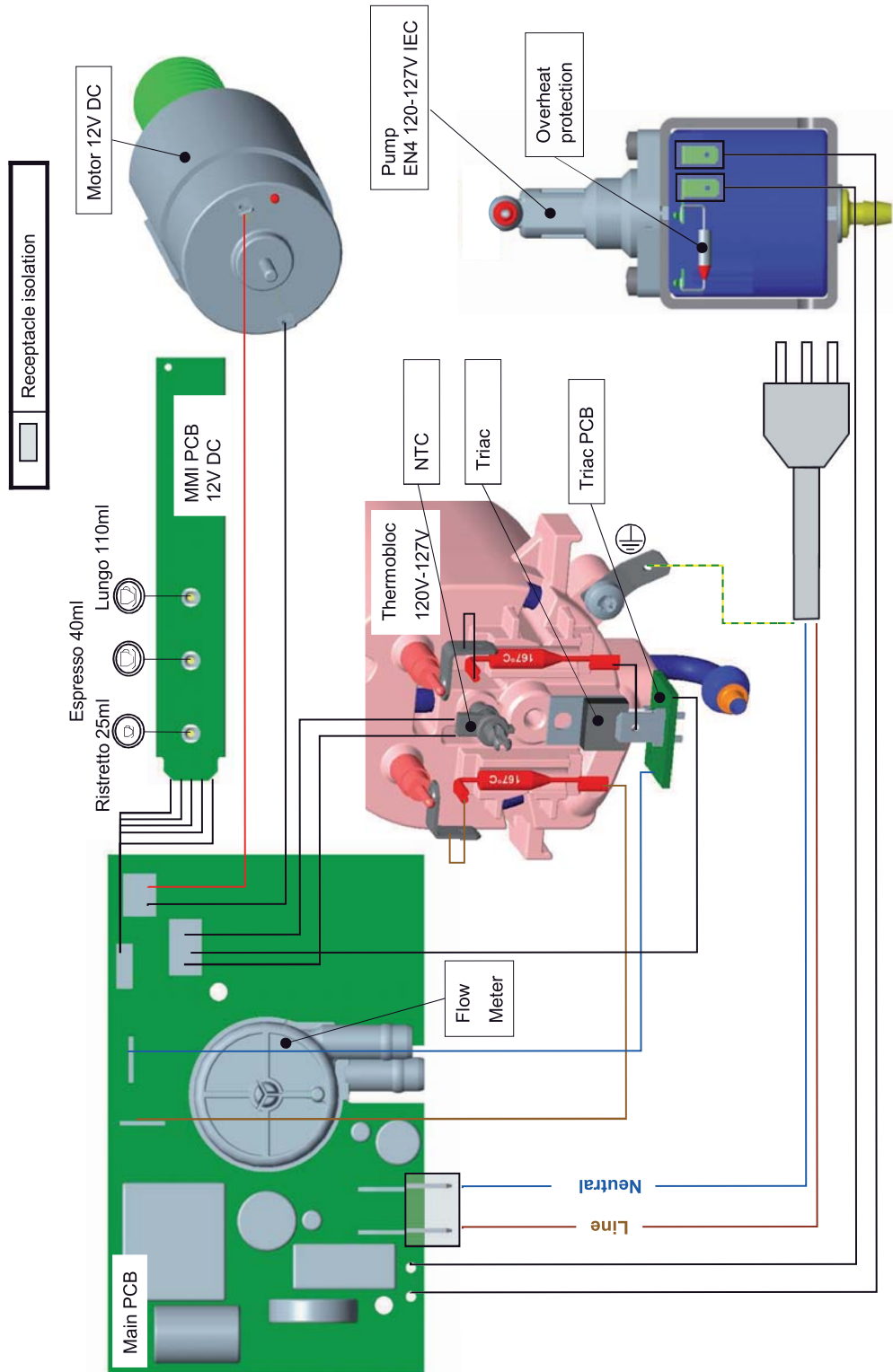



7.5.4 Wiring diagram 127 V IEC (Mexico)

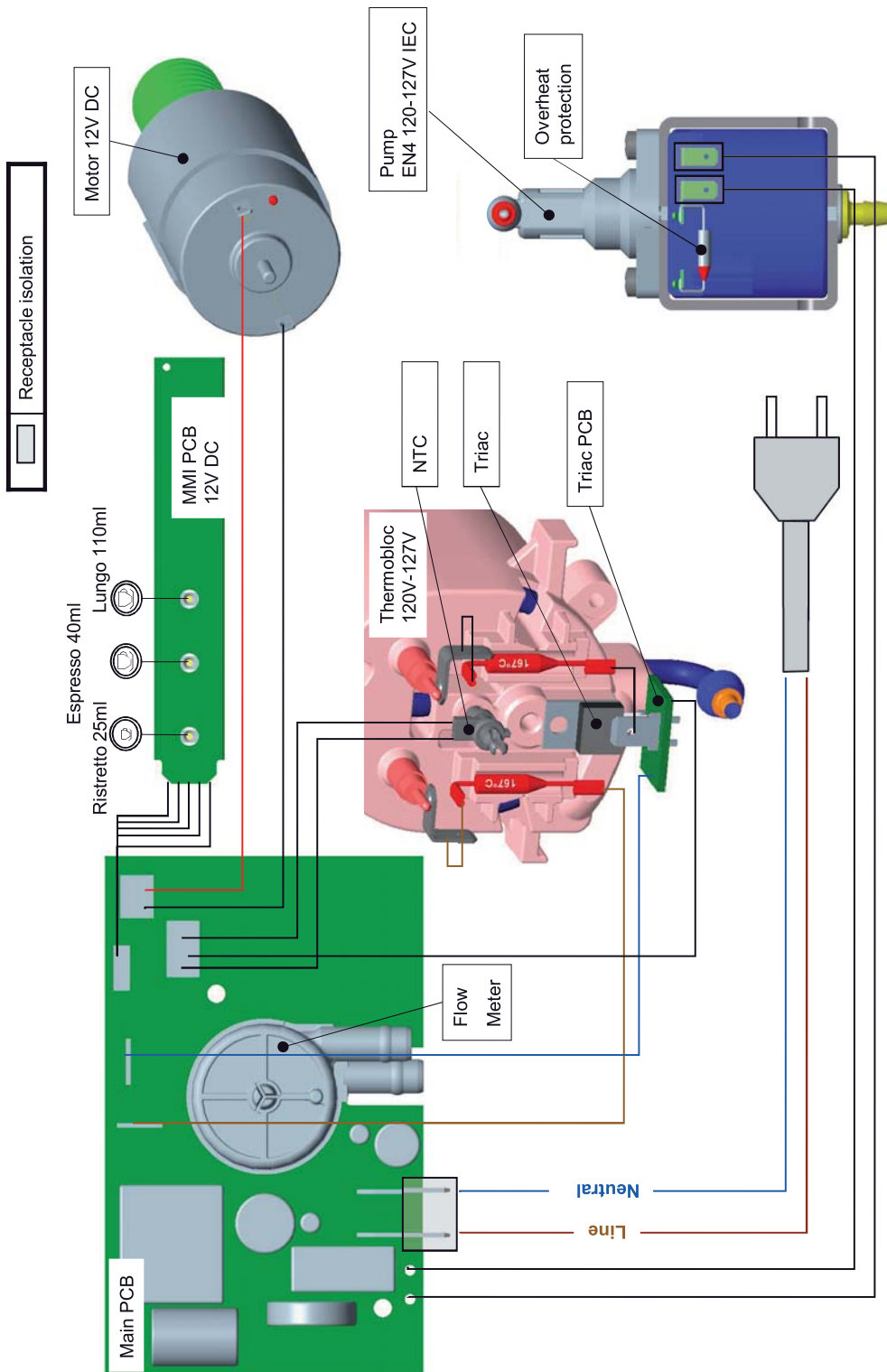



7.5.5 Wiring diagram 100 V IEC (Japan)

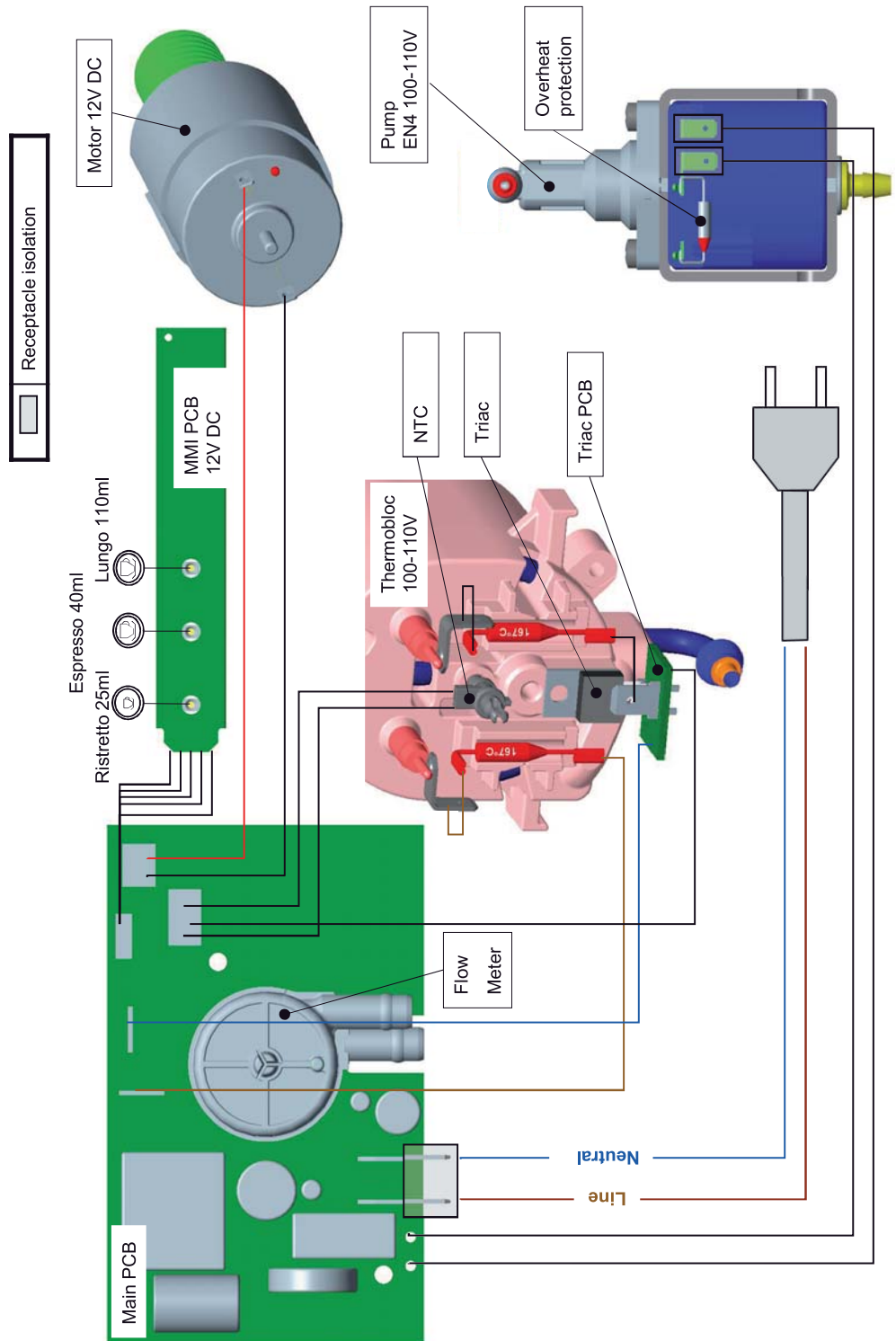



7.5.6 Wiring diagram 110 V IEC (Taiwan)

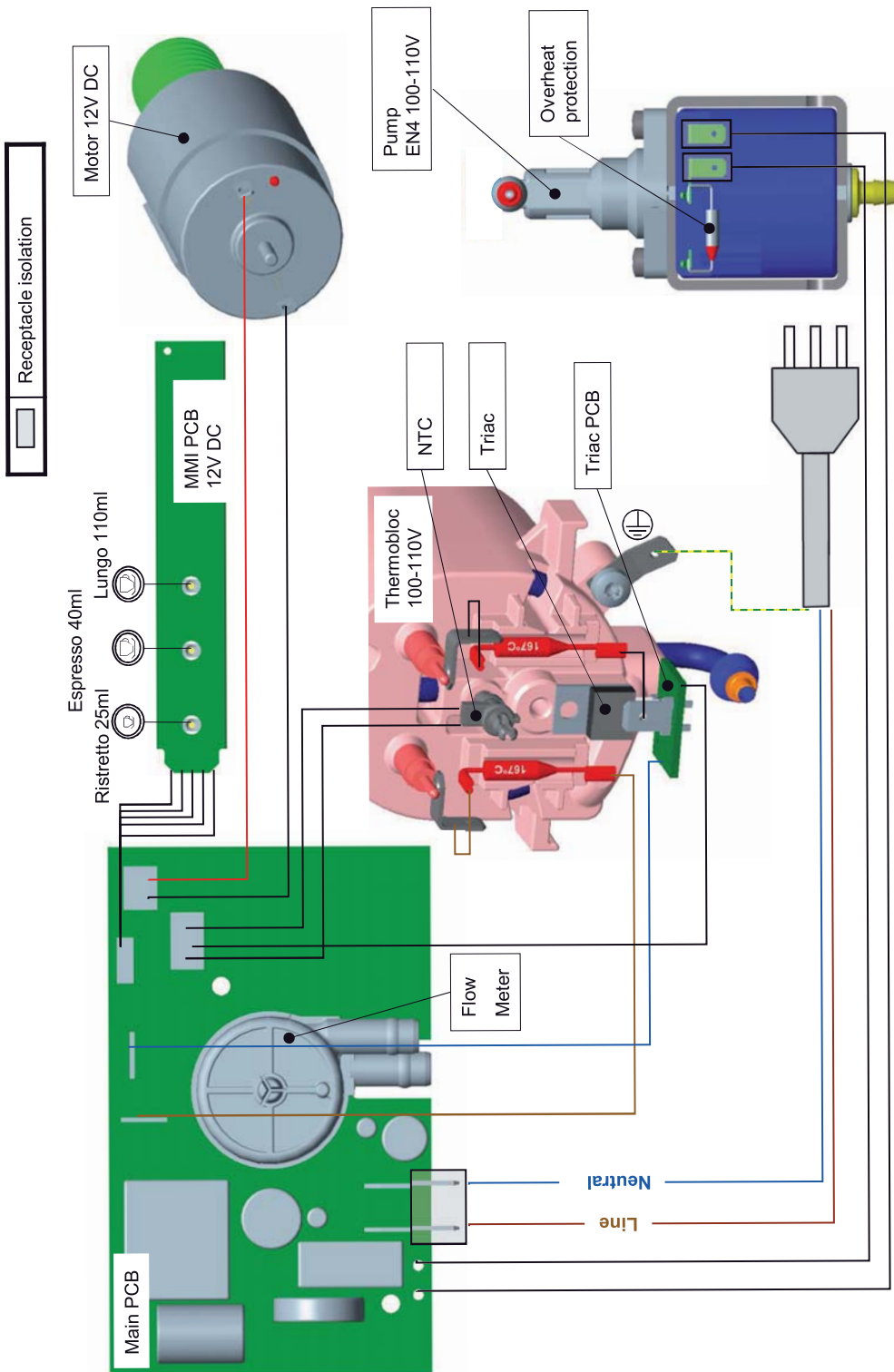



8 FUNCTION TESTS

8.1 Safety instructions

Some function tests are performed with an energized, partly opened coffee machine.



Danger of electrocution!

Mains voltage inside the coffee machine.

Do not touch any live part while performing tests.



Danger of burns!

Hot parts and water under pressure inside the coffee machine.

Do not touch any hot parts while checking for leakages!

Always wear protective goggles.

8.2 Required equipment

8.2.1 Overview

i Symbolic illustration of function test equipment.

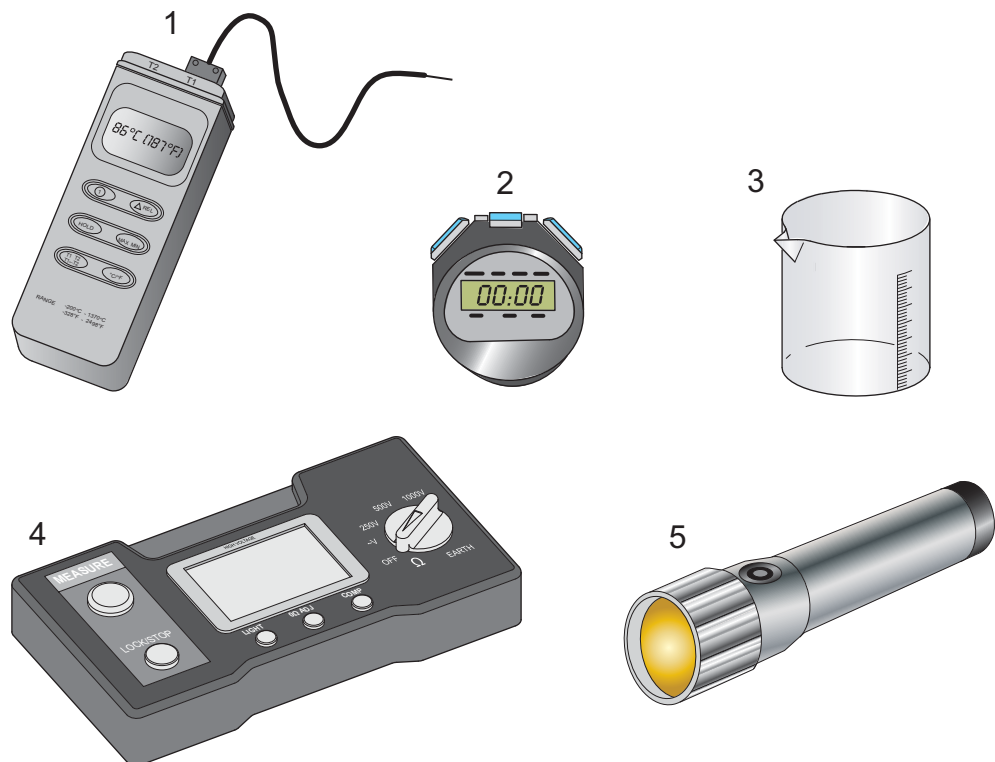

- 1) Electronic thermometer
- 2) Timer
- 3) Measuring cup

- 4) Test equipment for protective earth continuity test and protective insulation test
- 5) Flashlight



8.3 Measure coffee temperature

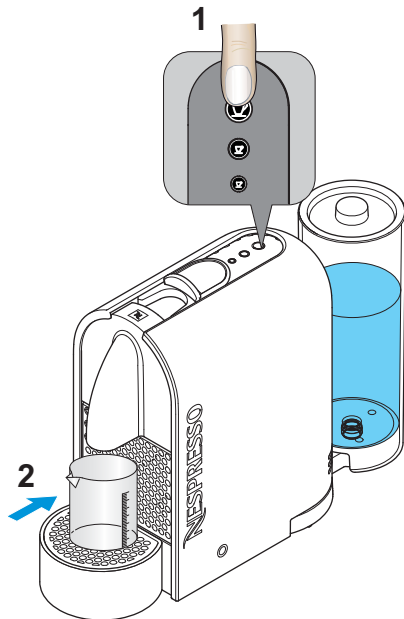

- 1) Start coffee machine.
- 2) Place a measuring cup on cup support.

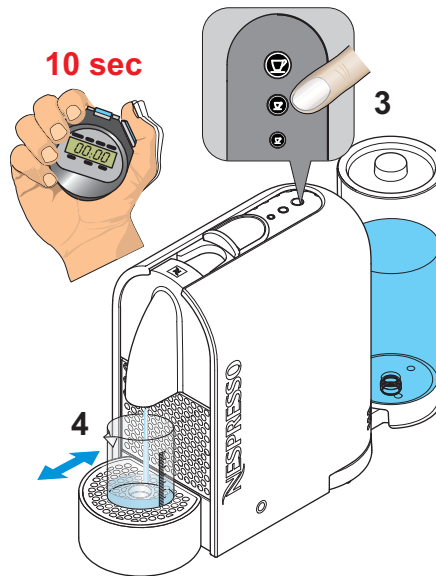

- 3) Preheat coffee outlet with hot water:
 1. Press Lungo button or close the slider.
 2. Wait 10 sec.
 3. Press button again to stop (or pull the sticker).
- 4) Empty measuring cup and place it back on cup support.

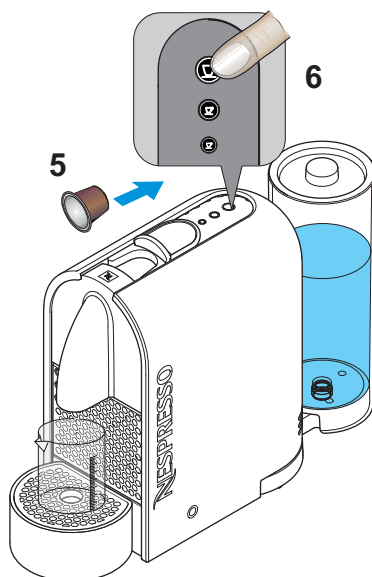

- 5) Insert capsule (Cosi is best suited).
- 6) Press the Lungo button again.

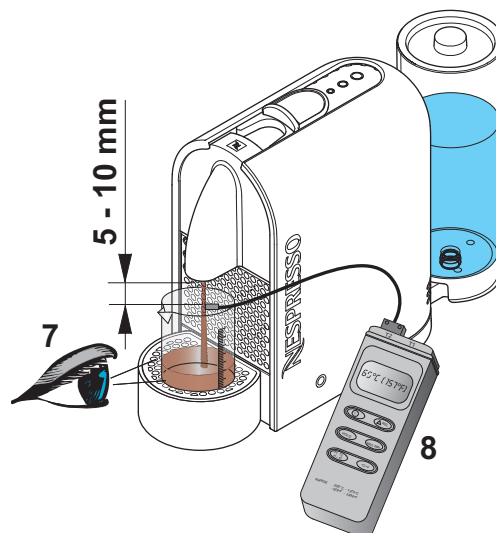

- 7) Wait until the measuring cup contains 20 ml of coffee.
- 8) Then measure the coffee temperature approx. 5-10 mm under the coffee outlet.

☞ The coffee temperature should be $86\text{ °C} \pm 3\text{ °C}$ ($187\text{ °F} \pm 5.4\text{ °F}$).



8.4 Tightness and leakage checks

This test must be performed:

- each time a part of the water circuit has been removed or replaced
- to confirm the tightness of the water circuit under pressure.



Dangerous mains voltage inside the coffee machine!
Do not touch any parts under voltage while checking for leakages!



Dangerous hot parts under pressure inside the coffee machine!
Do not touch any hot/pressurized parts while checking for leakages!
Always wear protective goggles.

8.4.1 Preparations

i The prepared capsule will not be perforated by the blades and blocks the water flow through the capsule cage.

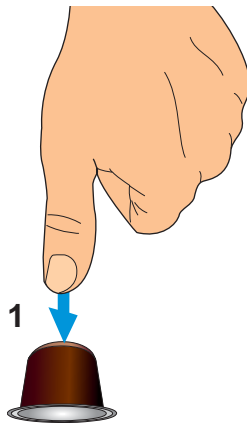

- 1) Prepare a capsule for the tightness and leakage checks: squash capsule by pressing the top with the thumb.

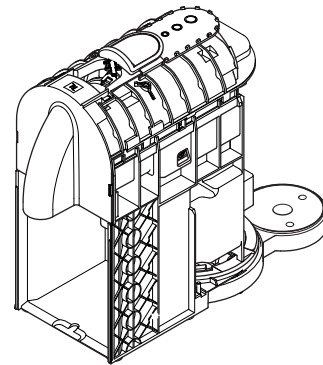

- 2) Remove top cover according to "General disassembly" on page 27.

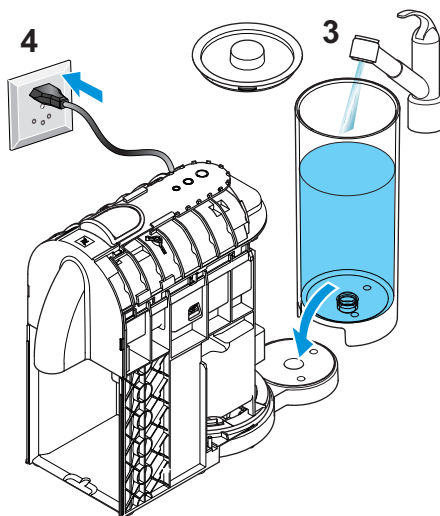

- 3) Fill water tank and place it on its arm.
4) Connect machine to mains.

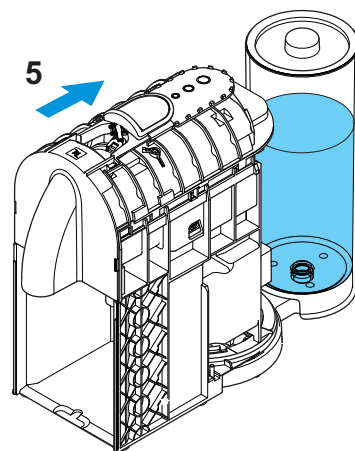

- 5) Turn machine ON by either pushing the slider or touching the controls. The machine heats up.



8.4.2 Test run

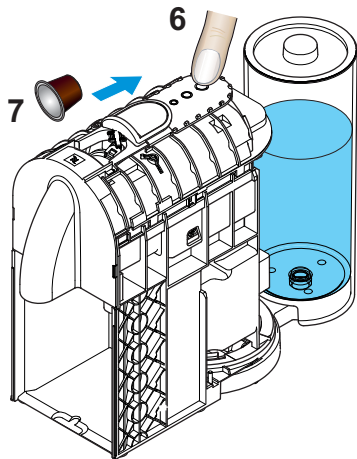

- 6) Touch the Lungo button.
- 7) Completely open the slider and insert the prepared capsule.

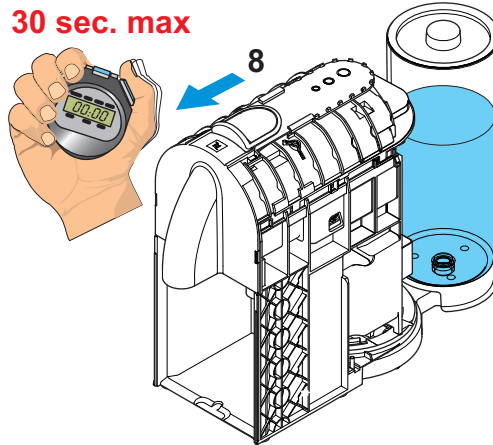

- 8) Close the slider. The pump starts to build up a pressure of approx. 20 bar.

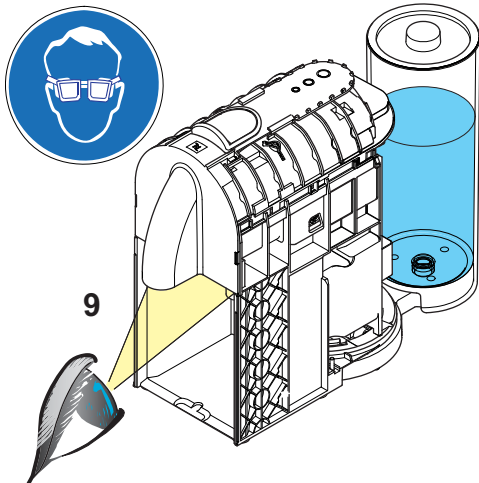

- 9) Check tightness of extraction chamber (drops or leakage).

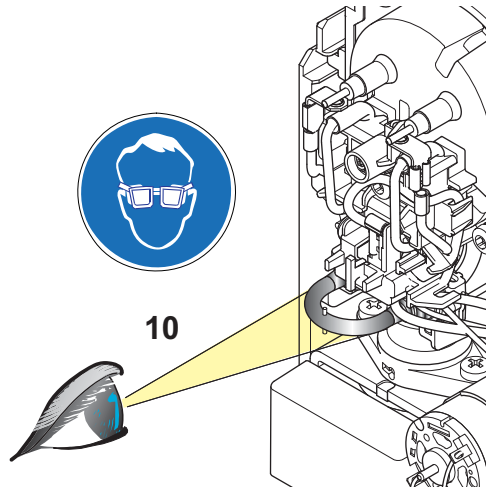

- 10) Check connections under pressure for audible and visible leaks. Pay special attention to the high pressure connector.

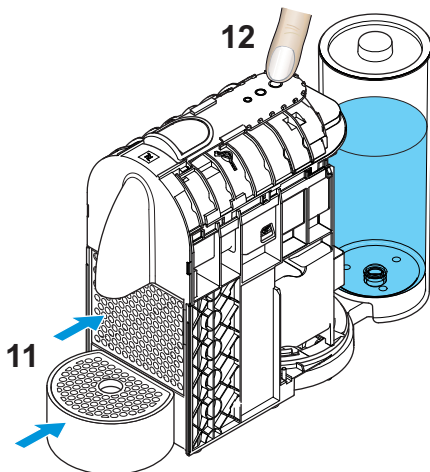

- 11) Insert capsule container with drip tray and attach cup support.
- 12) Touch Lungo button to stop pump and eject capsule.
- 13) Proceed with repair if needed or reassemble top cover.

Do not run the pump for more than 30 sec.

If machine stops during test, simply touch Lungo button again.

Always wear protective goggles during the test.

Note on point 9: A few drops of leakage can also appear if the capsule is not tight. In this case redo test with another capsule.

Let machine cool down, if capsule is blocked in the capsule compartment. Then open slider and remove blocked capsule.



8.5 Protective earth (PE) continuity test

8.5.1 What is the protective earth continuity test about?

This test is only necessary

- for class 1 equipment (three-wire power cord with protective earth)
- after a repair whenever a general disassembly was performed.

Therefore all U models have to be tested after general disassembly, except country-specific models (USA, Canada, Japan) without a protective earth connection (refer to "Wiring diagrams" on page 40 and following).

8.5.2 General

Legal regulation

In case of a repair/modification of the coffee machine, the repair centre is bound by law to protect the user/consumer by

- restoring the regular condition of the appliance and
- performing the mandatory tests according to applicable national regulations (e.g. DIN VDE 0701) or international regulations (e.g. EN/IEC 60335-1 "Safety of household and similar electrical appliances")

Description

Protective earth continuity measurements are made between the protective earth terminal of the power plug and the thermoblock casing.

This test assures that

- the ground (earth) connection does not have an interruption between the power plug and the thermoblock
- the permissible ground resistance is less than 0.3 Ohms (with a test current of 200 mA DC).

Test equipment

Special test equipment is needed that complies with the regulations to perform protective earth continuity measurements. Detailed requirements and tolerances must be verified by your local authorities or measurement supplier in any case.

Test report

For legal reasons a repair or test report should be prepared and filed with following information

- customer (name, address)
- type and serial number of coffee machine
- date of repair/test(s)
- performed test(s)/measuring value(s)
- used test equipment
- signature

i Ask Nespresso for recommendations about test equipment.



8.5.3 Test sequence



Danger of electrocution!
Do not plug in the coffee machine during the protective earth continuity test.
Read and observe safety instructions in user manual of test equipment.

i This test sequence is only an example and has to be adapted to applicable national standards and regulations.

i Symbolic illustration of test equipment.

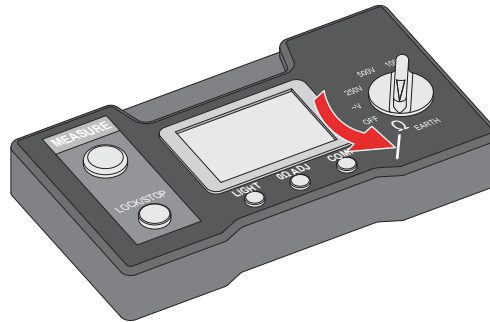
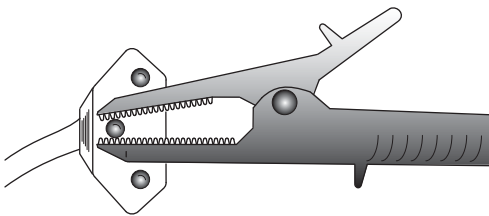

- 1) Connect black measuring cable to ground pin of power plug with an alligator clip (example shown: Swiss power plug).
- 2) Switch on test equipment and select protective earth continuity test.

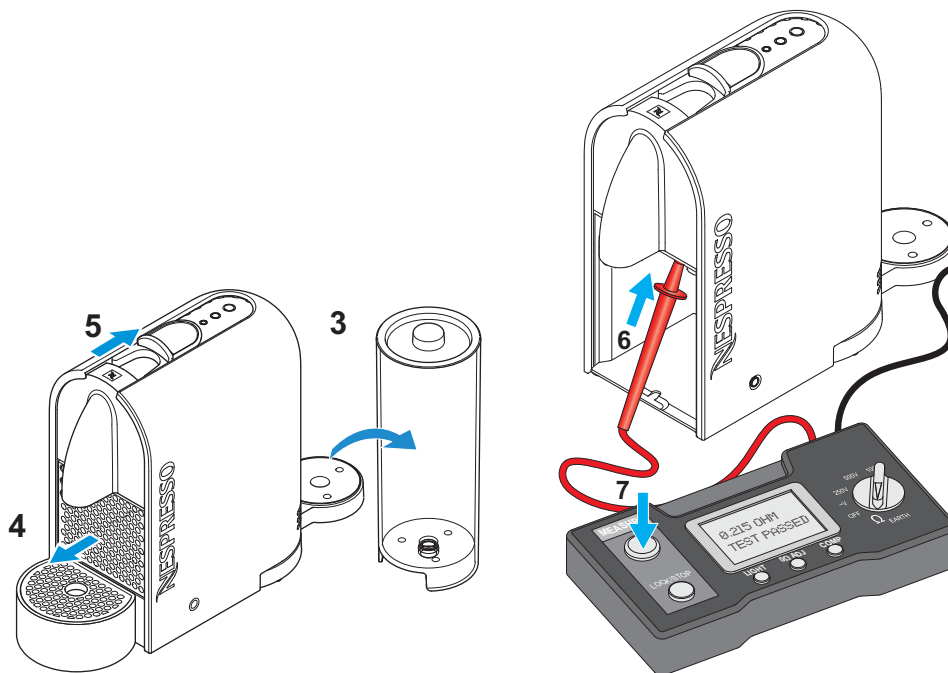

- 3) Remove water tank.
 - 4) Remove maintenance unit.
 - 5) Open slider.
 - 6) Insert tip of red test probe up into capsule ejection slot and touch thermoblock.
 - 7) Press "measure" button and read off displayed resistance.
- ☞ The resistance must be lower than 0.3 Ohm.**
- 8) Fill in measured value in a test report.



8.5.4 What to do if the protective earth continuity test fails

- Check/measure ground wire connection of power cord; replace if necessary.
- Check/measure ground connection terminal on thermoblock. Retighten terminal screw if necessary.

8.6 Protective insulation test

8.6.1 What is the protective insulation test about?

This test is necessary

- for class 1 and 2 equipment (with/without protective earth)
- after a repair whenever a general disassembly was performed.

8.6.2 General

Legal regulation

In case of a repair/modification of the coffee machine, the repair centre is bound by law to protect the user/consumer by

- restoring the regular condition of the appliance and
- performing the mandatory tests according to applicable national regulations (e.g. DIN VDE 0701) or international regulations (e.g. EN/IEC 60335-1 "Safety of household and similar electrical appliances").

Description

The insulation test

- assures that wiring and insulation of the coffee machine fulfill the normative requirements after a repair,
- rates the insulation capability of the coffee machine,
- is a very dangerous test because of a high test voltage (500 V DC).

For the insulation test, phase and neutral wire are shunted at the power plug. Then a test voltage is applied between phase/neutral and selected parts of the coffee machine.

Test equipment

Special test equipment is needed that complies with the regulations to perform insulation and withstanding voltage tests. Detailed requirements and tolerances must be verified with your local authorities or measurement supplier in any case.

Ideally the test equipment has a national power socket for testing, so that the coffee machine can be plugged in directly. Otherwise a special shunt is necessary to connect the phase and neutral pin of the coffee machine's power plug.

Test report

For legal reasons a repair or test report should be prepared and filed with following information

- customer (name, address)
- type and serial number of coffee machine

i Perform the protective earth (PE) continuity test at first, if it is mandatory.

i Ask Nespresso for recommendations about test equipment.



- date of repair/test(s)
- performed test(s)/measuring value(s), test points
- used test equipment
- signature

8.6.3 Test sequence



Danger of electrical shock/short circuit!
Do not plug in the coffee machine during insulation test.



Danger of electrical shock!
Do not touch tip of test probes.
Do not touch metallic parts of coffee machine during test.
Read and observe safety instructions in user manual of test equipment.

- 1) Connect the phase and neutral pin of the power plug together with a test adapter (procured by the repair centre).
- 2) Connect the black measuring cable to the test adapter (see image).
- 3) Switch on test equipment and select an insulation test voltage of 500 V DC.

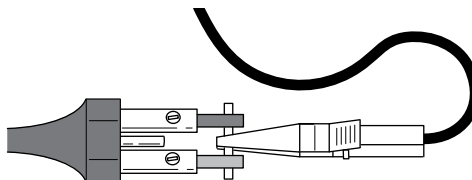

i This test sequence is only an example and has to be adapted to applicable national standards and regulations.

i Use a short circuit plug or special alligator clips etc. as substitute for this test adapter.

i Symbolic illustration of test equipment.

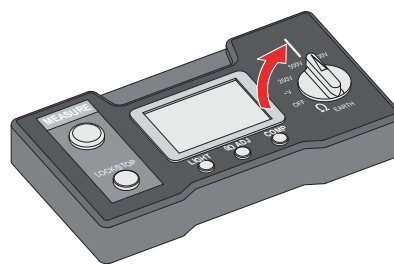

- 4) Touch magnet (5) with red test probe.
- 5) Press "measure" button.
- 6) Read off displayed insulation resistance or test result.

The insulation resistance must always be higher than 300 kOhm (300,000 Ohm).

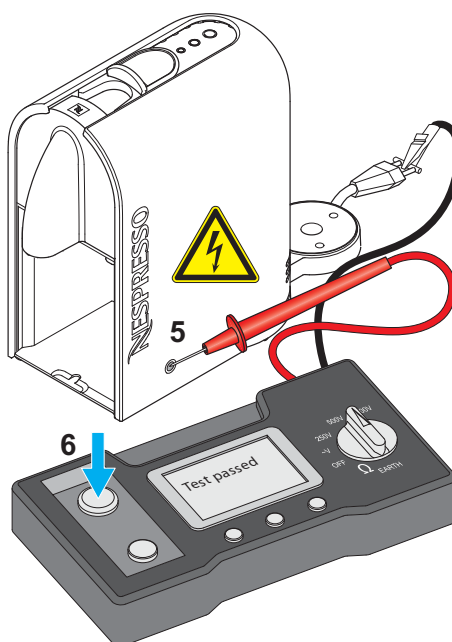

i Some test equipment displays test passed or failed instead of the insulation resistance.



FUNCTION TESTS

i By looking into the capsule ejection slot form below, metallic parts of the thermoblock are visible on both sides of the capsule cage.

- 7) Touch slider with red test probe.
- 8) Press "measure" button.
- 9) Read off displayed insulation resistance or test result.
- 10) Insert tip of red test probe up into capsule ejection slot and touch thermoblock.
- 11) Press "measure" button.
- 12) Read off displayed insulation resistance or test result.
- 13) Touch ground pin of power plug with red test probe.
- 14) Press "measure" button.
- 15) Read off displayed insulation resistance or test result.

ⓘ The insulation resistance must be always higher than 300 kOhm (300'000 Ohm).

- 16) Switch off test equipment.
- 17) Short red with black test probe to make sure that test voltage is discharged.
- 18) Fill in results in a test report.

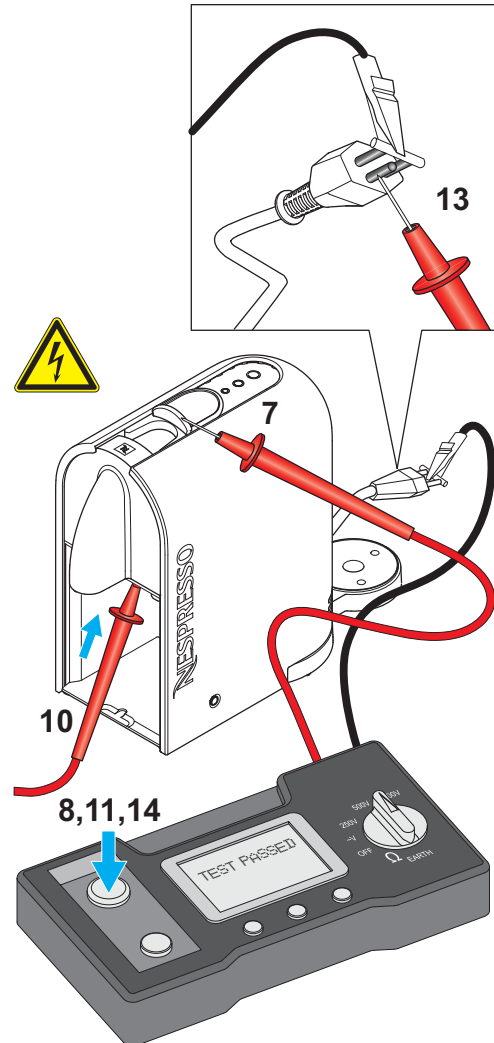

8.6.4 What to do if the insulation test fails



Risk of damage!

A sparkover can damage the electronic control board etc.

- Assume that the coffee machine is defect after a failed insulation test.
- Check thermoblock, especially connections.
- Check temperature sensor (NTC).
- Check wiring and locate fault. After fault clearance proceed with troubleshooting check list (see page 23).



9 EXPLOSION DRAWINGS

9.1 C50 Explosion drawing

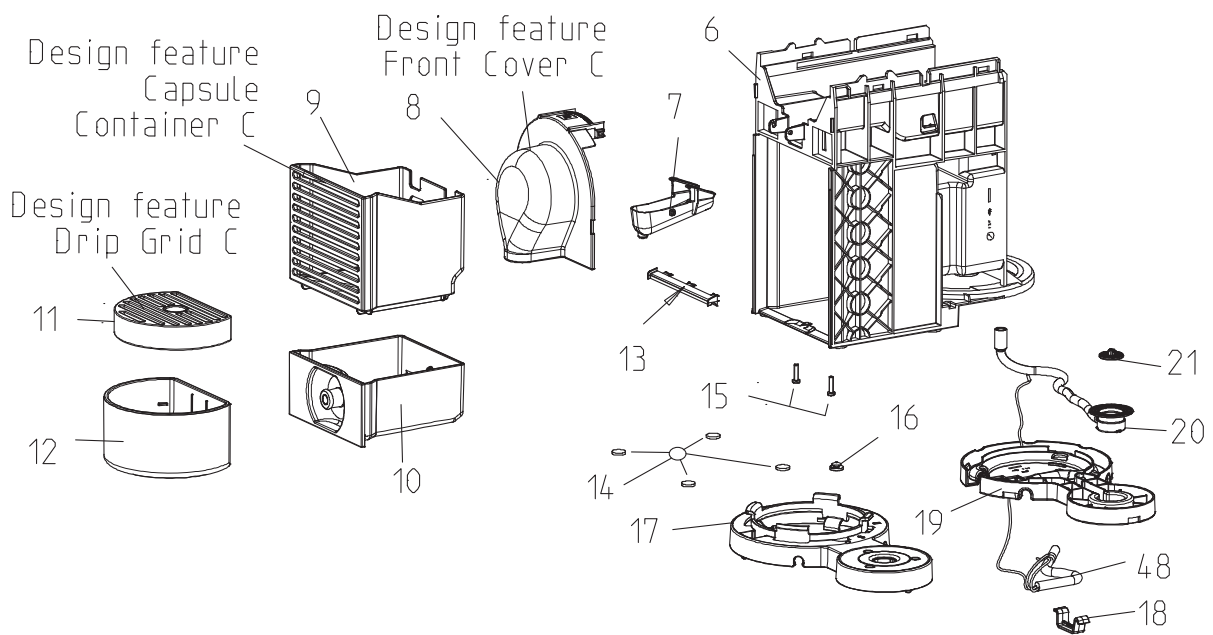
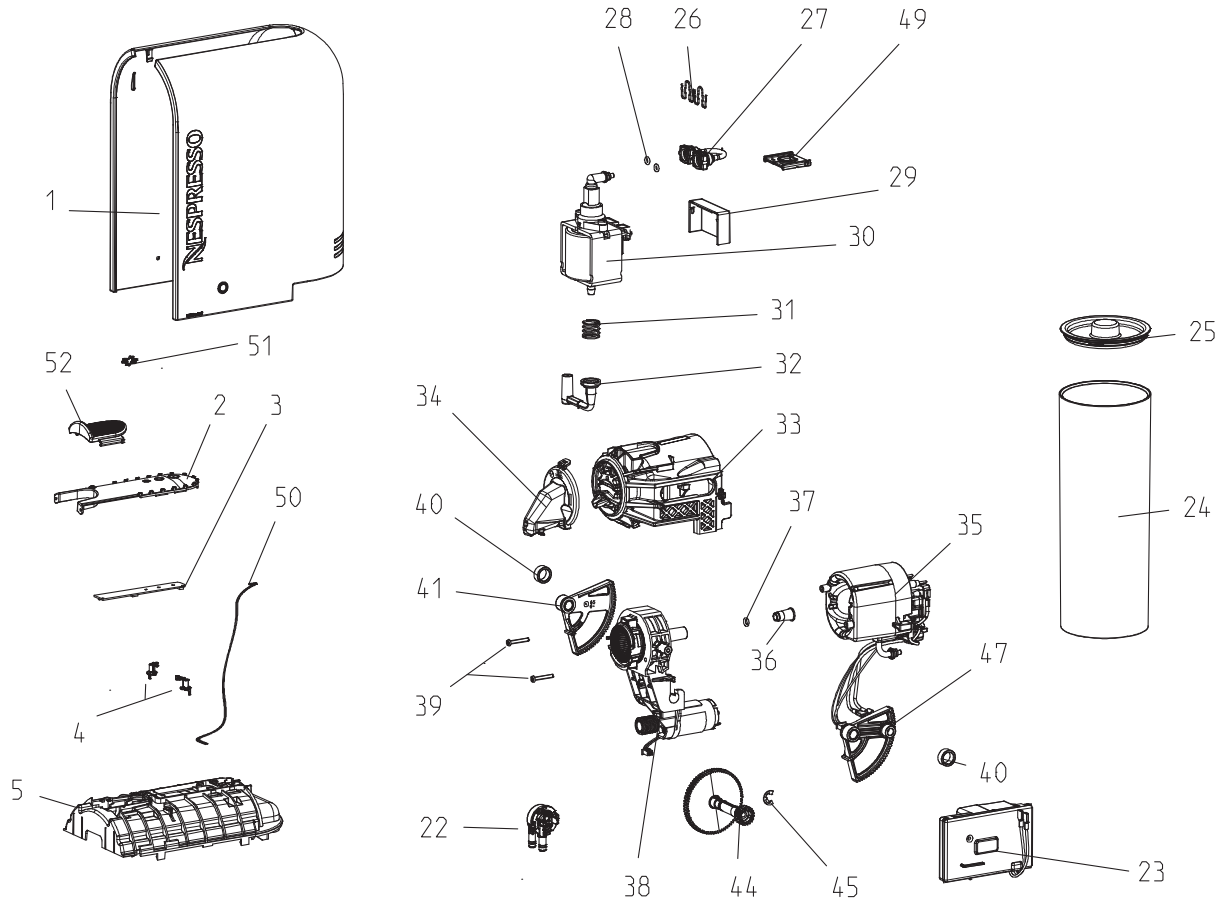



9.2 D50 Explosion drawing

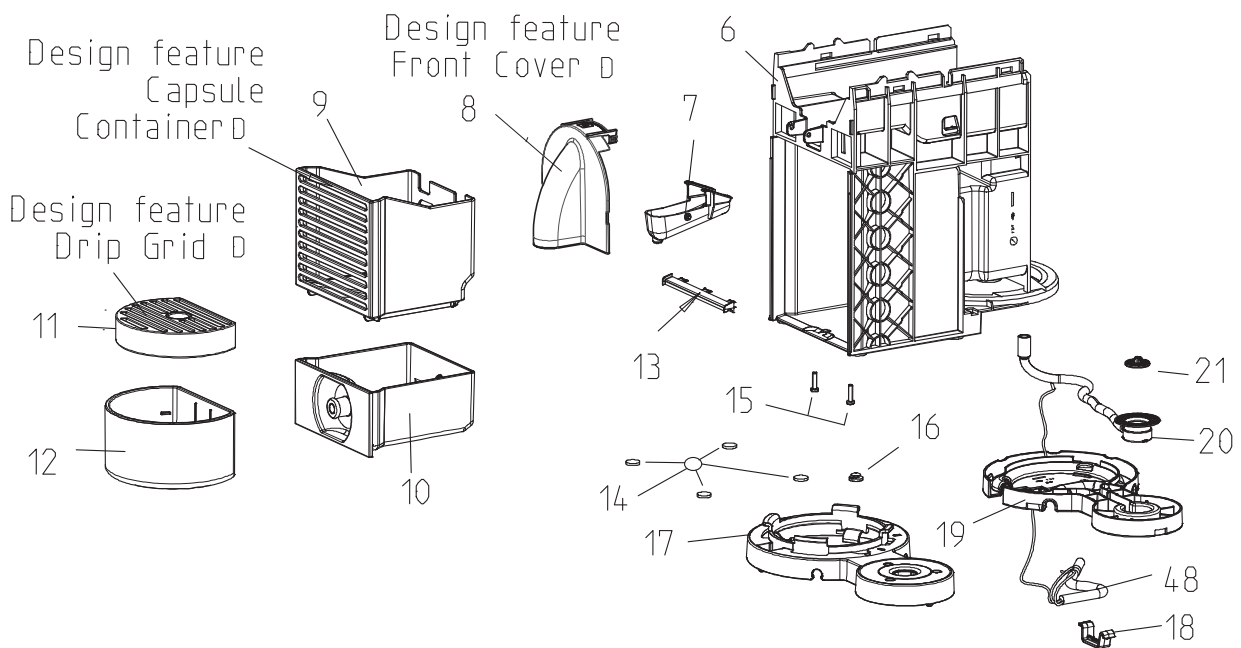
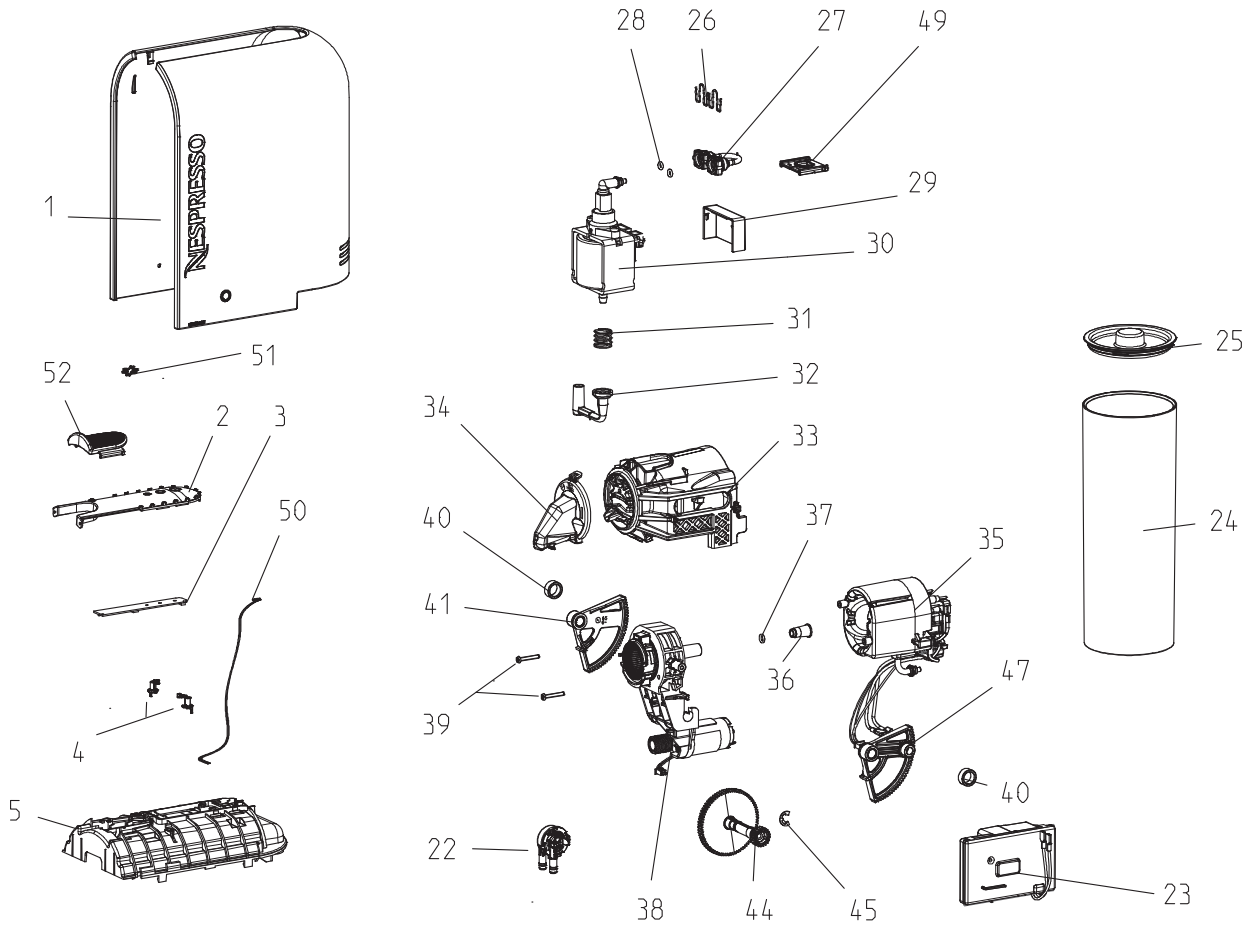



10 PARTS LIST

10.1 Nespresso C50 and D50

Explo. Pos.	Drawing, Part	Type	Component
1	29127-1	A	Cover black
1	29127-2	A	Cover cream
1	29127-3	A	Cover taupe
1	29127-4	A	Cover orange
2	29204	P	Blind
3	29503	A	Touch pad PCB
4	29206	P	Ratchet
5	29205	P	Print cover
6	29140	A	Chassis
7	29311	P	Drop stop
8	29202	P	Front cover D
8	29233	P	Front cover C
9	93255	P	Capsule container D
9	93254	P	Capsule container C
10	93258	A	Drip Tray
11	93257	P	Drip Grid D
11	93256	P	Drip Grid C
12	93259	A	Cup support
12	93260	A	Cup support
12	93261	A	Cup support
12	93262	A	Cup support
12	93263	A	Cup support
12	93264	A	Cup support
13	29247	P	Water guiding
14	29905	P	Elastic stop
15	29903	P	PT Li Schr In6rd 30x12
16	29246	P	Rubber foot
17	29128	A	Pivot top_65
17	29132	A	Pivot top_75
17	29133	A	Pivot top_UL
18	29504	P	Cable bracket
19	29212	P	Pivot bottom_65
19	29228	P	Pivot bottom_75
19	29230	P	Pivot bottom_UL
20	29400	P	Low pressure connector WT
21	29244	P	Filter
22	17002	A	Flowmeter FM PCB



PARTS LIST

Explo. Pos.	Drawing, Part	Type	Component
23	29118	A	Electronic device
24	93252	A	Water tank
25	93253	P	Water tank lid
26	29911	P	Connector clip
27	18147	P	High pressure connector
28	29907	P	O-Ring 3.4 x 1.9
29	29241	P	Pump isolation
30	18287-1	P	Pump EN4 220-240V
30	18287-2	P	Pump EN4 120-127V UL
30	18287-3	P	Pump EN4 100-110V
30	18287-4	P	Pump EN4 120-127V IEC
31	29238	P	Pump support spring
32	29401	P	Low pressure connector pump
33	29123	A	BU housing
34	29301	P	Steam cover
35	29116-1	A	TB Assembled 220-240V
35	29116-2	A	TB Assembled 120V UL
35	29116-3	A	TB Assembled 100V
35	29116-4	A	TB Assembled 120V IEC
36	29242	P	TB sleeve
37	29908	P	O-Ring seal tb tube
38	29141	A	Capsule cage with motor and worm wheel
39	29902	P	Li Schr In6rd M3x20
40	29306	P	Bush bearing
41	29124	A	Gear lever left
42			
43			
44	29307	P	Gear wheel
45	90106-10	P	Circlip D=7
46		A	
47	29125	A	Gear lever right
48	29509-1	A	Connection Cable EU compl. ass.
48	29509-2	A	Connection Cable CH compl. ass.
48	29509-3	A	Connection Cable UK compl. ass
48	29509-4	A	Connection Cable AU compl. ass
48	29509-5	A	Connection Cable IL compl. ass
48	29509-6	A	Connection Cable AR compl. ass
48	29509-7	A	Connection Cable ZA compl. ass
48	29509-8	A	Connection Cable KR compl. ass
48	29509-9	A	Connection Cable CL compl. ass
48	29509-10	A	Connection Cable CN compl. ass
48	29510	A	Connection Cable UL compl. ass



Explo. Pos.	Drawing, Part	Type	Component
48	29513	A	Connection Cable JP compl. ass.
48	29512-1	A	Connection Cable BR w label 127V
48	29512-2	A	Connection Cable BR w label 220V
48	29511	A	Connection Cable TW compl. Ass
49	29402	P	Pump support
50	29521	A	Touch pad cable
51	29121	A	Spring packet
52	29120	A	Slider



PARTS LIST